

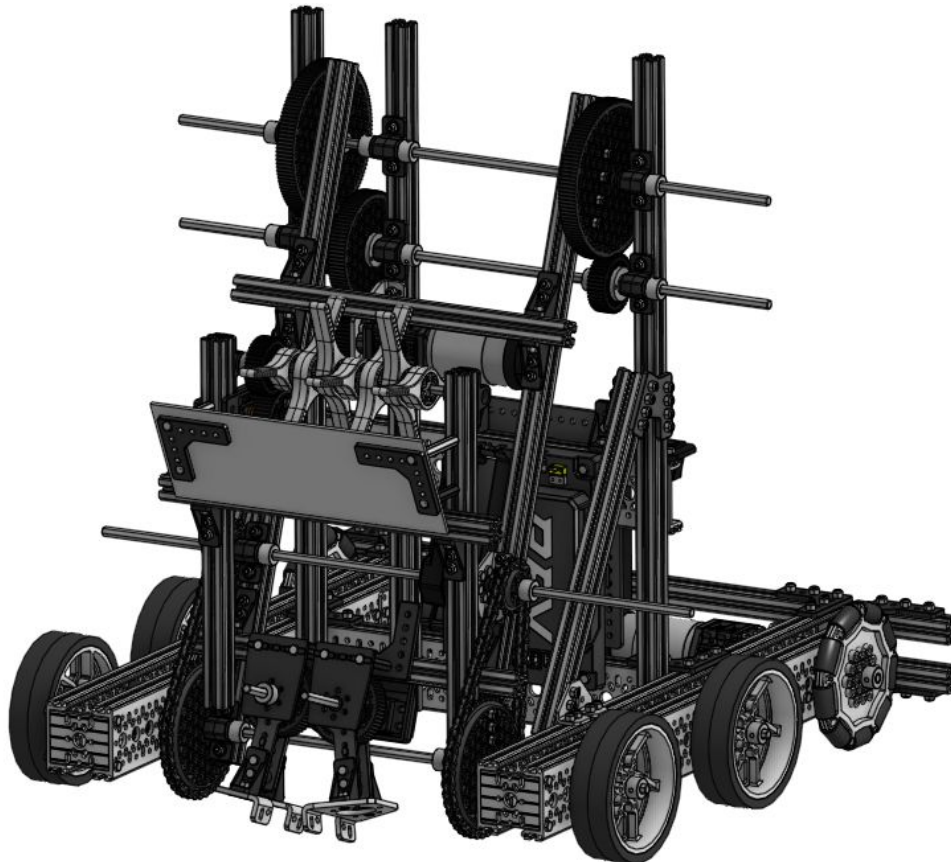

2024-25 REV DUO FTC Starter Bot Build Guide



Part number	Description	QTY.	Part number	Description	QTY.
REV-31-1302	12V Slim Battery	1	REV-41-1335	60 Tooth Plastic Gear	3
REV-31-1387	Switch Cable and Bracket	1	REV-41-1337	90 Tooth Plastic Gear	1
REV-31-1595	Control Hub	1	REV-41-1338	10 Tooth #25 Sprocket	8
REV-31-1596	Driver Hub	1	REV-41-1339	15 Tooth #25 Sprocket	2
REV-31-2983	REV USB PS4 Compatible Gamepad	1	REV-41-1343	40 Tooth #25 Sprocket	2
REV-41-1097	Smart Robot Servo	2	REV-41-1347	5mm x 75mm Hex Shaft	2
REV-41-1124	M3 x 20mm Hex Cap Screw	4	REV-41-1348	5mm x 90mm Hex Shaft	6
REV-41-1125	M3 x 35mm Hex Cap Screw	4	REV-41-1359	M3 x 8mm Hex Cap Screw	262
REV-41-1147	High Strength Hex Hub	3	REV-41-1360	M3 x 16mm Hex Cap Screw	38
REV-41-1166	Battery Holder Plate	1	REV-41-1361	M3 Nyloc Nut	234
REV-41-1190	90mm Omni Wheel	2	REV-41-1362	5mm x 400mm Hex Shaft	5
REV-41-1267	90mm Grip Wheel	4	REV-41-1365	#25 Roller Chain	6
REV-41-1291	HD Hex Motor	3	REV-41-1431	15mm Extrusion - 225mm	7
REV-41-1600	UltraPlanetary gearbox Kit & HD Hex Motor	3	REV-41-1432	15mm Extrusion - 420mm - 90° Ends	7
REV-41-1303	15mm Plastic Motion Bracket	3	REV-41-1433	15mm Metal Bent Core Hex Motor Bracket V2	3
REV-41-1304	15mm Plastic Rod End Bracket	4	REV-41-1491	M3 Standoff - 30mm	6
REV-41-1305	15mm Plastic 90 Degree Bracket	15	REV-41-1492	M3 Standoff - 40mm	8
REV-41-1308	15mm Plastic 30 Degree Bracket	4	REV-41-1493	M3 Standoff - 45mm	2
REV-41-1317	15mm Bearing Pillow Block	11	REV-41-1621	UltraPlanetary Outside Mounting Bracket	2
REV-41-1319	15mm Plastic Servo Bracket	2	REV-41-1623	UltraPlanetary Bent Mounting Bracket	3
REV-41-1321	15mm Plastic Lap Corner Bracket	15	REV-41-1687	U Channel Endcap	4
REV-41-1323	15mm Spacer	3	REV-41-1702	Tensioning Bushing - 39mm	8
REV-41-1324	3mm Spacer	28	REV-41-1762	45mm x 15mm C Channel - 408mm	4
REV-41-1326	Through Bore Bearing - Short	21	REV-41-1767	45mm x 15mm C Channel - 248mm	2
REV-41-1327	Shaft Collars	33	REV-41-1828	Aluminum Servo Horn V2	1
REV-41-1328	Servo Shaft Adapter	1	REV-41-1839	450mm x 300mm x 4mm Corrugated Plastic Sheet	1
REV-41-1329	Through Bore Bearing - Long	15	REV-41-2702	DUO Flap Wheels (medium)	7
REV-41-1333	125 Tooth Plastic Gear	2	REV-41-1373	Hook and Loop Fastener, 13.5mm x 2m	2
REV-41-1334	45 Tooth Plastic Gear	4	REV-41-1161	Black Zipties	4

Cut List

Extrusion can be cut with either a hand-held hacksaw or with a band saw. Be sure that the pieces are properly secured, ideally with clamps, before cutting. Using a circular or chop saw is NOT recommended.

400mm Hex Shaft x 1		
Length	QTY.	Assembly
175mm*	1	Intake
225mm*	1	Forearm

***Note that this is one cut that will result in the two needed shaft lengths.**

Related Guides

Chain Tool instructions

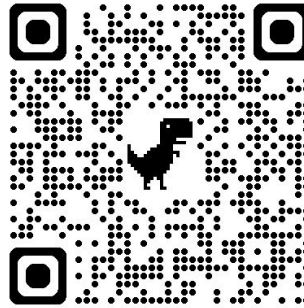

<https://docs.revrobotics.com/duo-build/motion/sprockets-and-chain/chain-tool>

Ultra Planetary Assembly Instructions

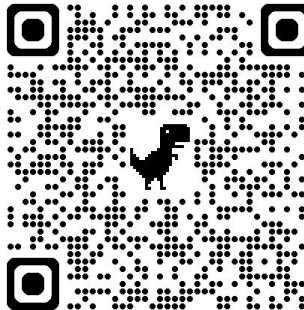

<https://docs.revrobotics.com/rev-crossover-products/ultraplanetary/assembly-instructions>

Intake Assembly

Bill of Materials

Part number	Description	QTY.
REV-41-1359	M3 x 8mm Hex Cap Screws	15
REV-41-1360	M3 x 16mm Hex Cap Screws	14
REV-41-1361	M3 Nyloc Nuts	17
REV-41-1362	175mm cut Hex Shaft	1
REV-41-1327	Shaft Collars	2
REV-41-1329	Through Bore Bearing, Long	2
REV-41-1493	M3 Standoff - 45mm	2
REV-41-1491	M3 Standoff - 30mm	2
REV-41-2702	Flap Wheels - Medium	7
REV-41-1334	45 Tooth Plastic Gear	1
REV-41-1335	60 Tooth Plastic Gear	1
REV-41-1321	15mm Plastic Lap Corner Bracket	2
REV-41-1305	15mm Plastic 90 Degree Bracket	2
REV-41-1317	15mm Bearing Pillow Blocks	2
REV-41-1319	15mm Plastic Servo Bracket	1
REV-41-1097	Smart Robot Servo	1
REV-41-1828	Aluminum Servo Horn V2	1
REV-41-1431	15mm Extrusion - 225mm	3
REV-41-1839	Custom Cut Corrugated Plastic	1

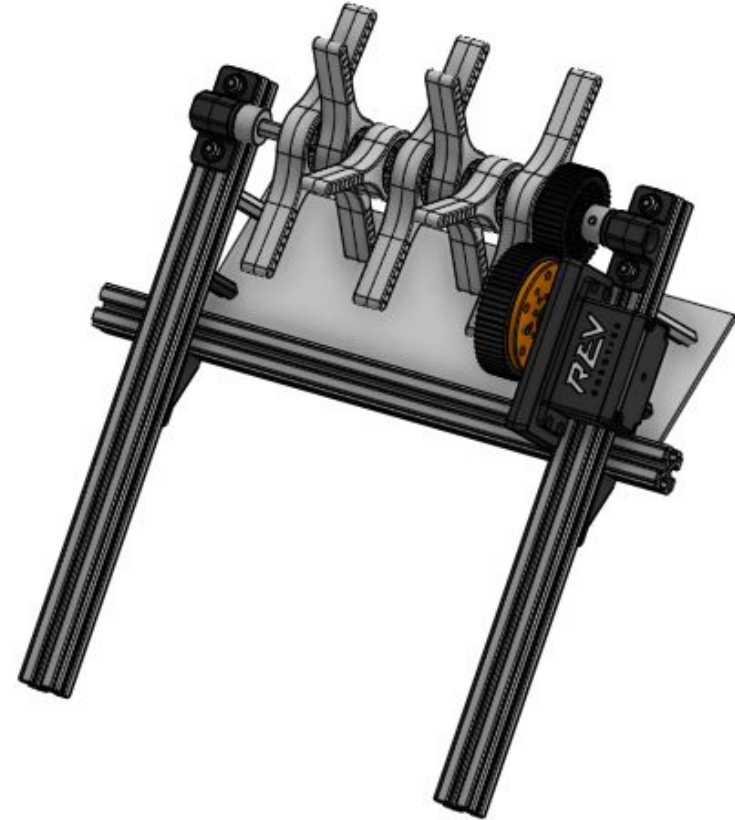

1

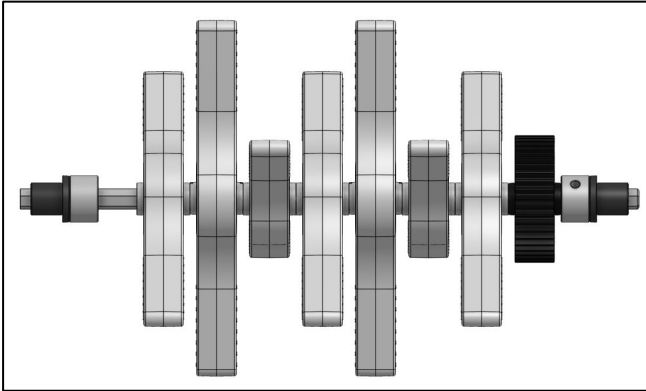

Get:

- 1 - 175mm cut Hex Shaft
- 2 - Through Bore Bearing, Long
- 2 - Shaft Collars
- 7 - Flap Wheels - Medium
- 1 - 45 Tooth Gear

Slide the above onto the the hex shaft. When you slide on the flap wheels, rotate each one once more than the last to look as shown. Secure with shaft collar and set screw.

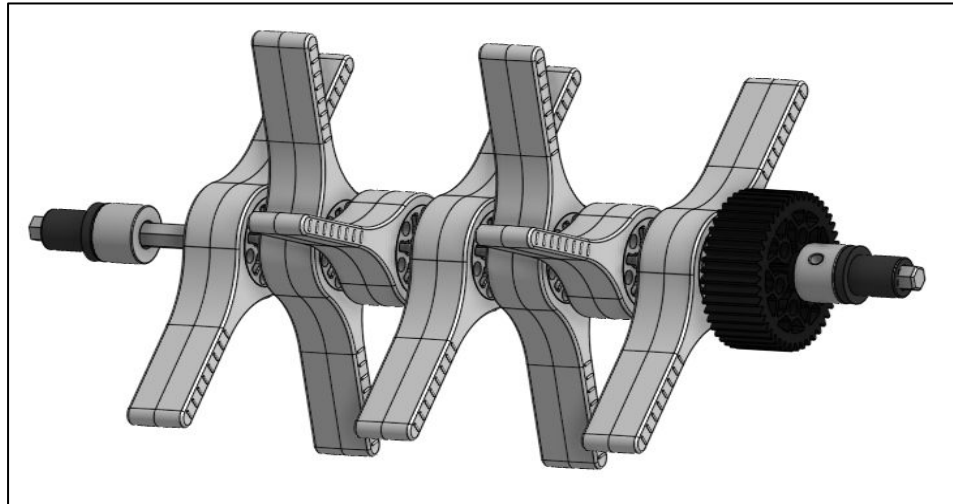

2

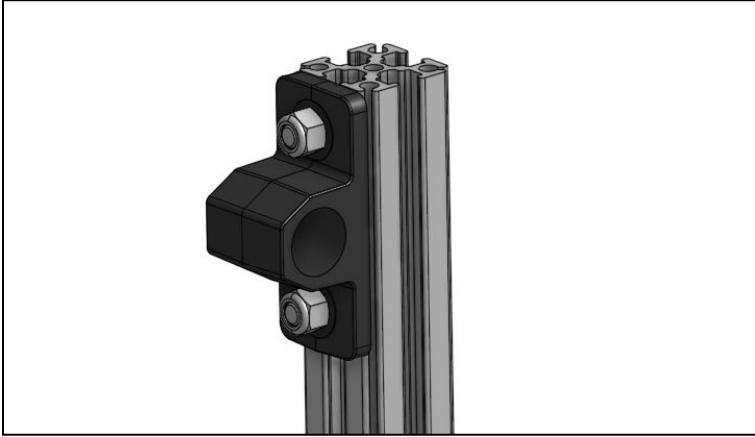

Get:

- 2 - 15mm Bearing Pillow Blocks
- 4 - M3 x 8mm Hex Cap Screws
- 4 - M3 Nyloc Nuts
- 2 - 225mm Extrusion

Fasten the pillow bearing blocks onto the extrusion, putting the edge of the block flush with the end of the extrusion.

3

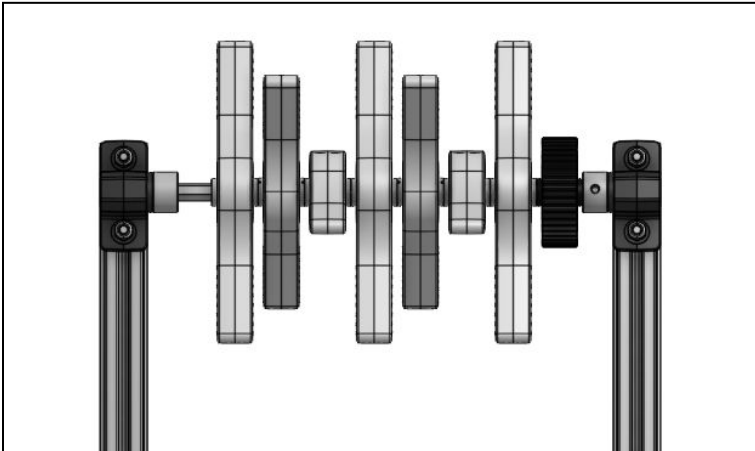

Get:

- 2 - 225mm Extrusion with Bearing Pillow Blocks

Slide the through bore bearings into the pillow blocks.

4

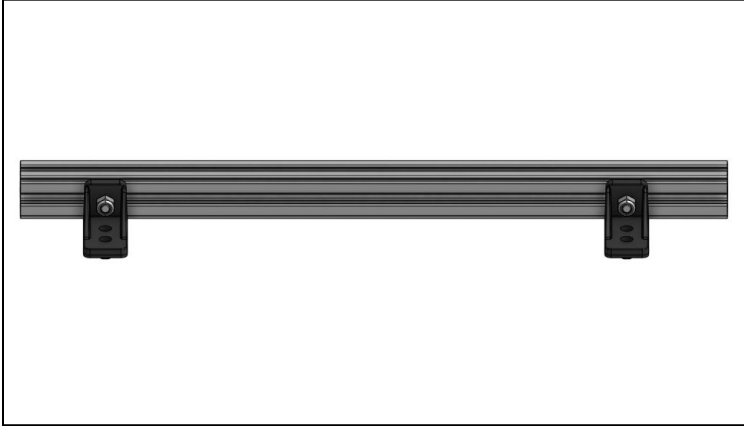

Get:

- 1 - 225mm Extrusion
- 2 - 15mm Plastic Lap Corner Bracket
- 2 - M3 x 8mm Hex Cap Screws
- 2 - M3 Nyloc Nuts

Slide two corner brackets onto the extrusion keeping it loose to adjust later.

5

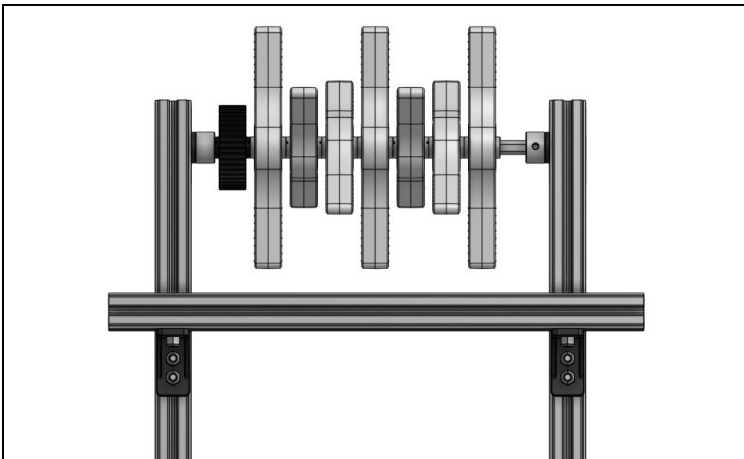

Get:

- 4 - M3 x 8mm Hex Cap Screws
- 4 - M3 Nyloc Nuts

Fasten the extrusion with the corner brackets on the opposite side to the pillow bearing blocks, tightening all nuts on the corner brackets.

6

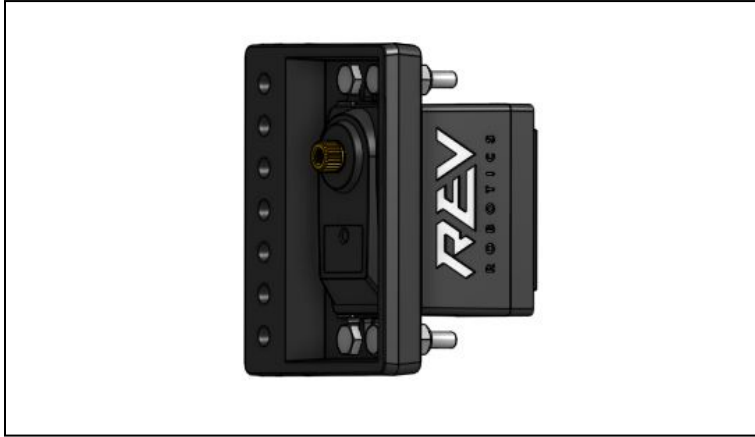

Get:

- 1 - Smart Robot Servo
- 1 - 15mm Plastic Servo Bracket
- 4 - M3 x 16mm Hex Cap Screws
- 4 - M3 Nyloc Nuts

Fasten a Smart Robot Servo to the servo bracket with 4 hex cap screws. Note the direction of the bracket, the output of the servo will be in the recessed side of the bracket. This will be important later to ensure gears are properly aligned.

7

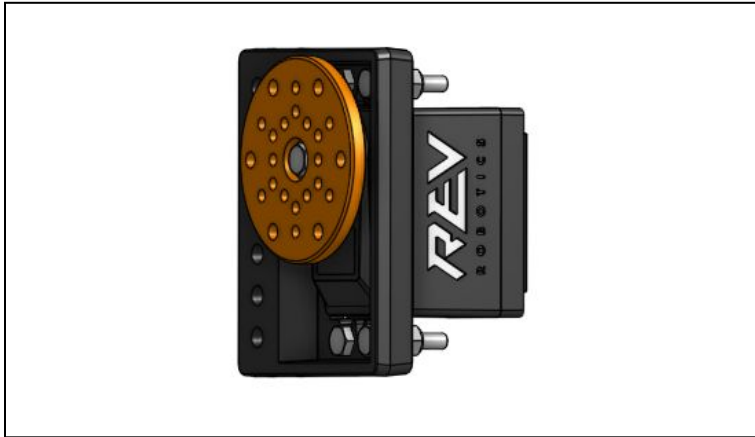

Get:

- 1 - Aluminum Servo Horn
- 1 - M3 x 8mm Hex Cap Screws

Fasten the aluminum servo horn onto the Smart Robot Servo.

8

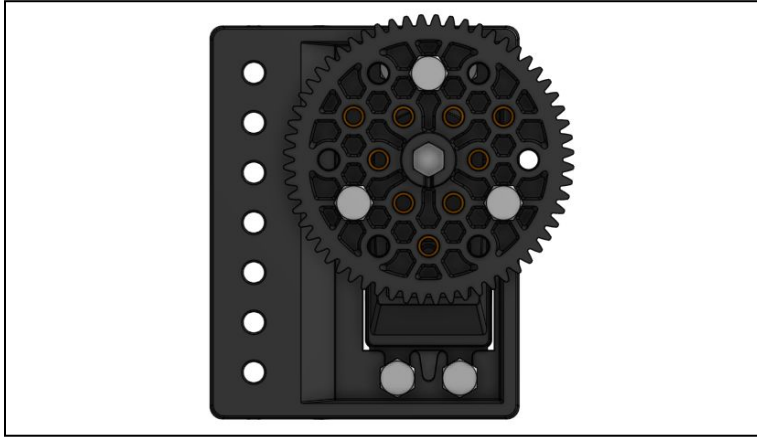

Get:

- 1 - 60 Tooth Plastic Gear
- 3 - M3 x 16mm Hex Cap Screws

Fasten the 60 tooth gear to the servo horn with three screws.

9

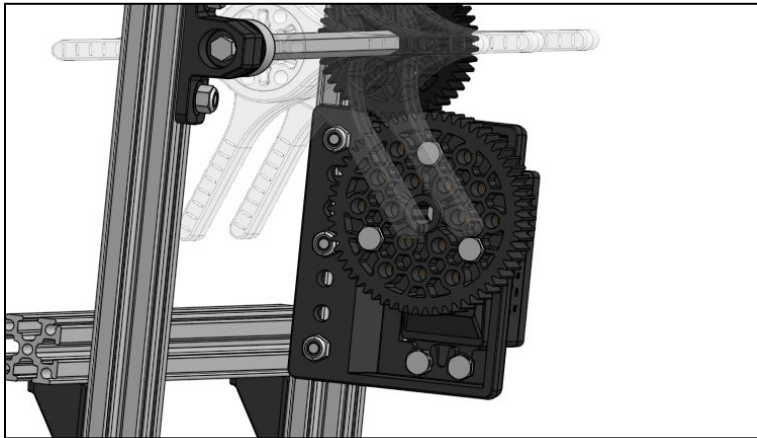

Get:

- 3 - M3 x 8mm Hex Cap Screws
- 3 - M3 Nyloc Nuts

Fasten the servo bracket to the extrusion as shown with three screws. The 60 tooth gears should be making significant contact and interaction with the 45 tooth gear.

10

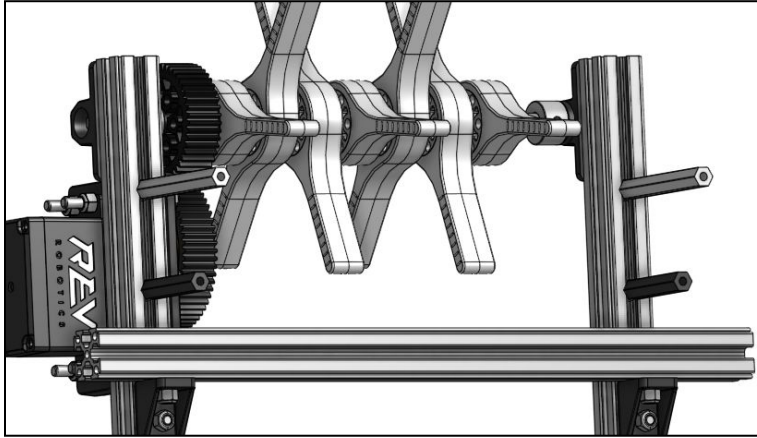

Get:

- 2 - M3 Standoff - 45mm
- 2 - M3 Standoff - 30mm
- 4 - M3 x 8mm Hex Cap Screws

Slide M3 screws into the extrusion and secure them with 45mm standoffs and 30mm standoffs as shown.

11

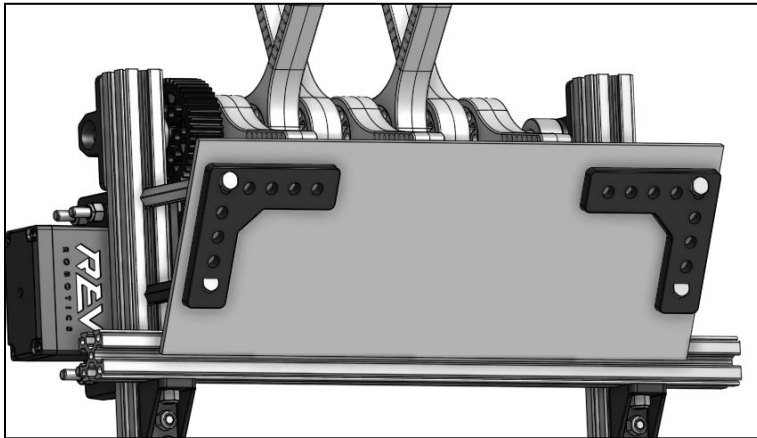

Get:

- 1 - Custom Cut Corrugated Plastic
- 2 - 15mm Plastic 90 Degree Bracket
- 4 - M3 x 16mm Hex Cap Screws

Measure and cut a corrugated that best fits your intake. Cut holes into your plastic for M3 screws and use two 90 degree brackets and 4 screws to secure the the plastic to the standoffs as shown.

Forearm and Claw Assembly

Bill of Materials Part 1 of 2

Part number	Description	QTY.
REV-41-1432	15mm Extrusion - 420mm - 90° Ends	2
REV-41-1431	15mm Extrusion - 225mm	3
REV-41-1321	15mm Plastic Lap Corner Bracket	10
REV-41-1359	M3 x 8mm Hex Cap Screw	48
REV-41-1360	M3 x 16mm Hex Cap Screw	12
REV-41-1124	M3 x 20mm Hex Cap Screw	2
REV-41-1125	M3 x 35mm Hex Cap Screw	4
REV-41-1361	M3 Nyloc Nut	54
REV-41-1433	15mm Metal Bent Core Hex Motor Bracket V2	1
REV-41-1317	15mm Bearing Pillow Block	3
REV-41-1097	Smart Robot Servo	1
REV-41-1319	15mm Plastic Servo Bracket	1
REV-41-1328	Servo Shaft Adapter	1
REV-41-1305	15mm Plastic 90 Degree Bracket	1
REV-41-1303	15mm Plastic Motion Bracket	3



Forearm and Claw Assembly

Bill of Materials Part 2 of 2

Part number	Description	QTY.
REV-41-1347	5mm x 75mm Hex Shaft	2
REV-41-1327	Shaft Collars	9
REV-41-1326	Through Bore Bearing - Short	3
REV-41-1324	3mm Spacer	8
REV-41-1304	15mm Plastic Rod End Bracket	4
REV-41-1491	M3 Standoff - 30mm	4
REV-41-1335	60 Tooth Plastic Gear	2
REV-41-1623	UltraPlanetary Bent Mounting Bracket	2
REV-41-1329	Through Bore Bearing - Long	3
REV-41-1300	Core Hex Motor	1
REV-41-1362	5mm x 400mm Hex Shaft	5
REV-41-1343	40 Tooth #25 Sprocket	2
REV-41-1339	15 Tooth #25 Sprocket	2
REV-41-1365	#25 Roller Chain - 62 Link Loop	2
REV-41-1323	15mm Spacer	3



1

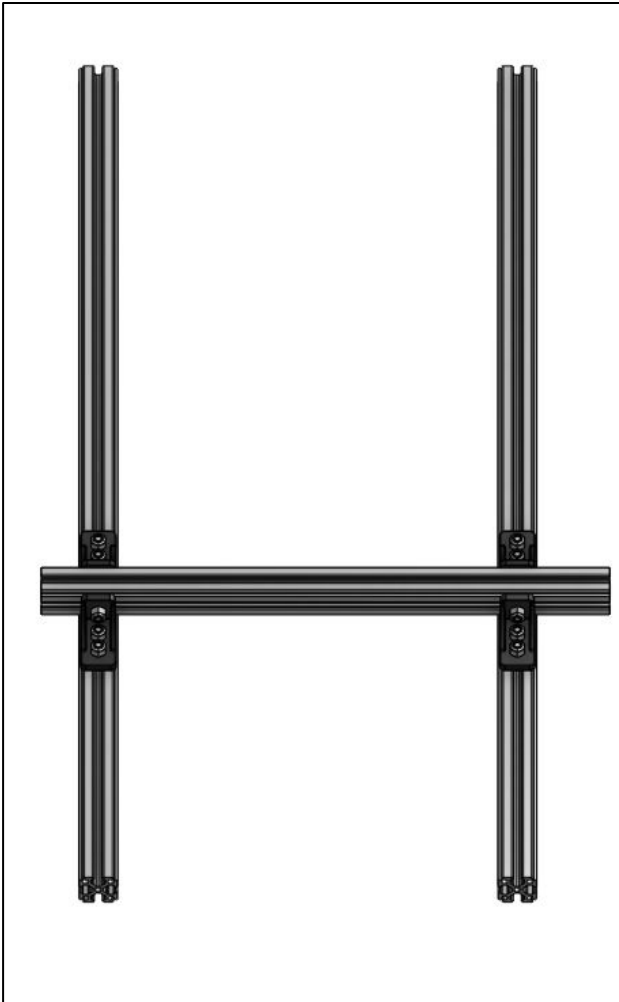

Get:

- 2 - 420mm Extrusion
- 1 - 225mm Extrusion
- 4 - 15mm Plastic Lap Corner Bracket
- 12 - M3 x 8mm Hex Cap Screws
- 12 - M3 Nyloc Nuts

Fasten the four corner brackets to the 225mm extrusion first then to the 420mm extrusion as shown.

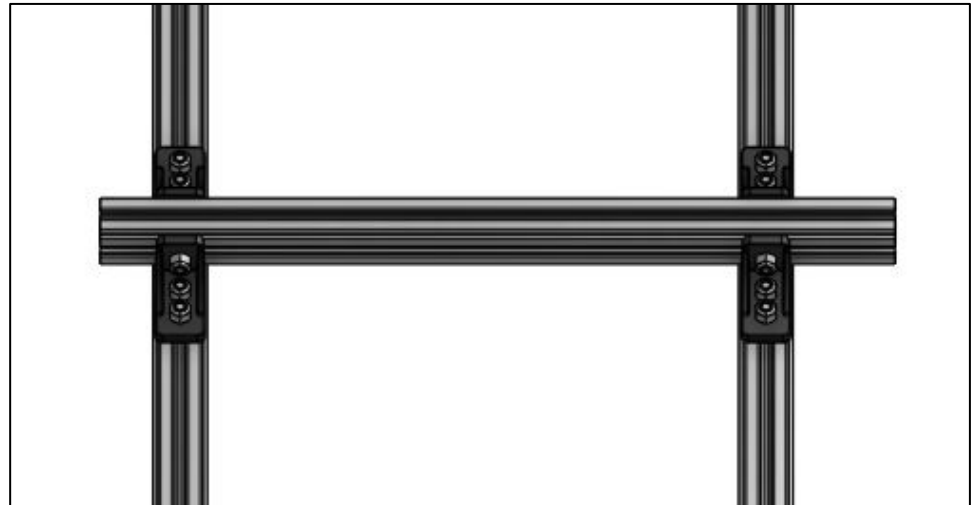

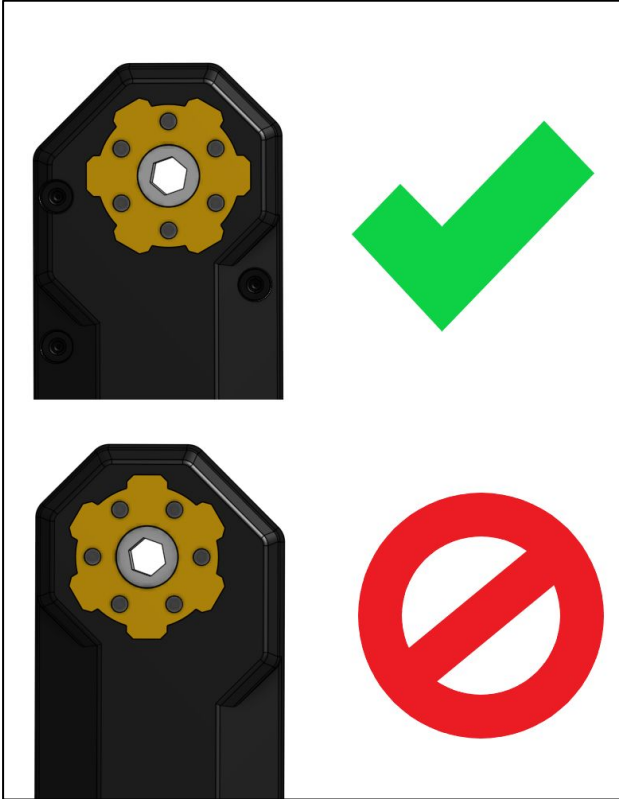

Get:

- 1 - 15mm Metal Bent Core Hex Motor Bracket
- 1 - Core Hex Motor
- 4 - M3 x 8mm Hex Cap Screws

Fasten a Core Hex Motor onto the motor bracket as shown. Note the mounting patterns are asymmetrical on the Core Hex Motor. If you are having trouble mounting the motor in the correct orientation, flip the motor.

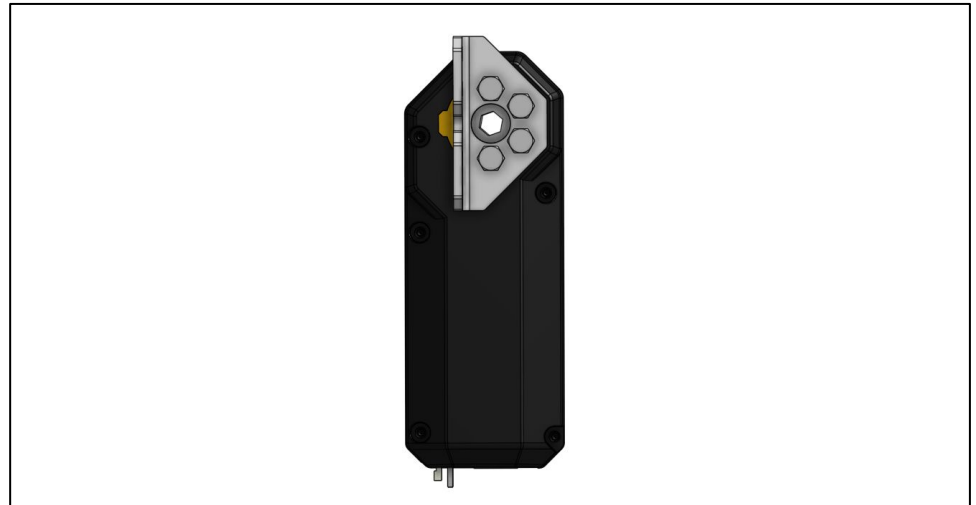

3



Get:

- 1 - 15mm Metal Bent Core Hex Motor Bracket
- 1 - 15mm Bearing Pillow Block
- 6 - M3 x 8mm Hex Cap Screws
- 6 - M3 Nyloc Nuts

Fasten the motor bracket and bearing block to the 420mm extrusion as shown.

4

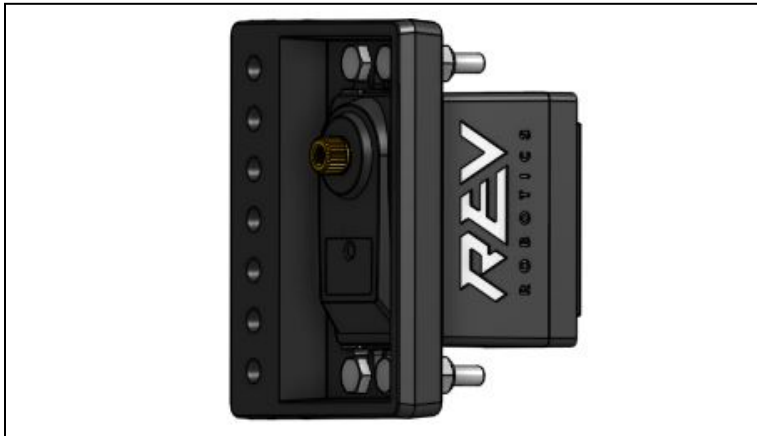

Get:

- 1 - Smart Robot Servo
- 1 - 15mm Plastic Servo Bracket
- 4 - M3 x 16mm Hex Cap Screws
- 4 - M3 Nyloc Nuts

Fasten a Smart Robot Servo to the servo bracket with 4 hex cap screws. Note the direction of the bracket, the output of the servo will be in the recessed side of the bracket. This will be important later to ensure gears are properly aligned.

5

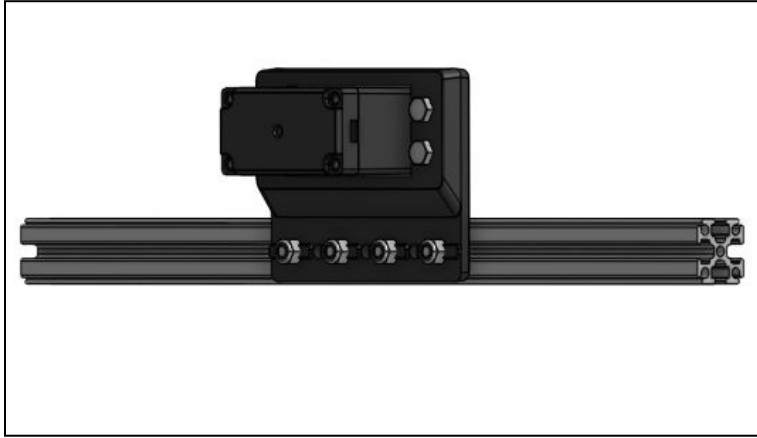

Get:

4 - M3 x 8mm Hex Cap Screws

4 - M3 Nyloc Nuts

Fasten the servo and bracket the 225mm extrusion as shown.

6

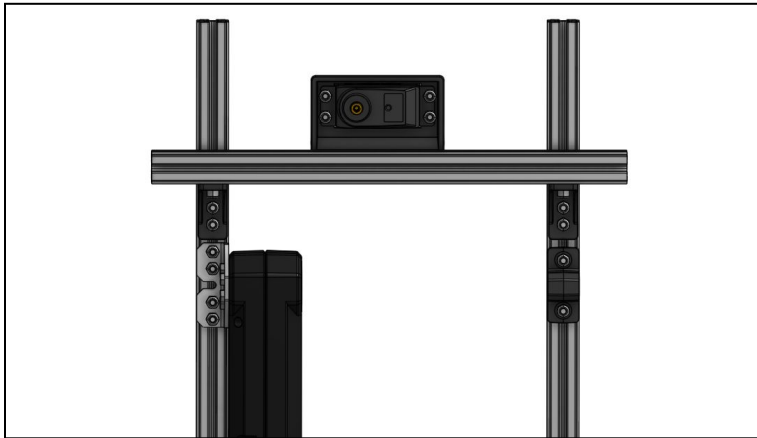

Get:

- 1 - 225mm Extrusion
- 2 - 15mm Plastic Lap Corner Bracket
- 6 - M3 x 8mm Hex Cap Screws
- 6 - M3 Nyloc Nuts

Fasten the two corner brackets to the 225mm extrusion first then to the 420mm extrusion as shown.

7

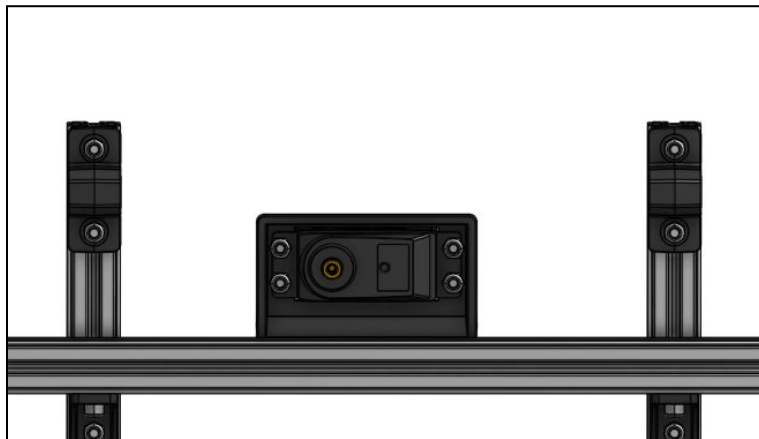

Get:

- 2 - 15mm Bearing Pillow Blocks
- 4 - M3 x 8mm Hex Cap Screws
- 4 - M3 Nyloc Nuts

Fasten the bearing blocks onto the extrusion, getting the edge of the block flush with the end of the extrusion.

8

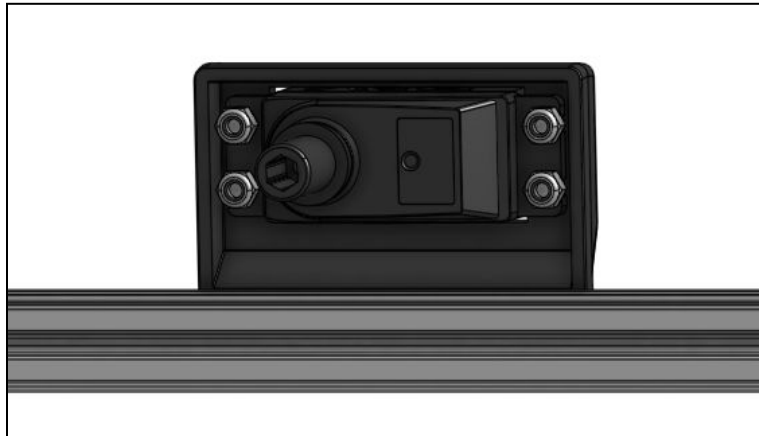

Get:

- 1 - Servo Shaft Adapter

Press the servo shaft adapter onto the servo.

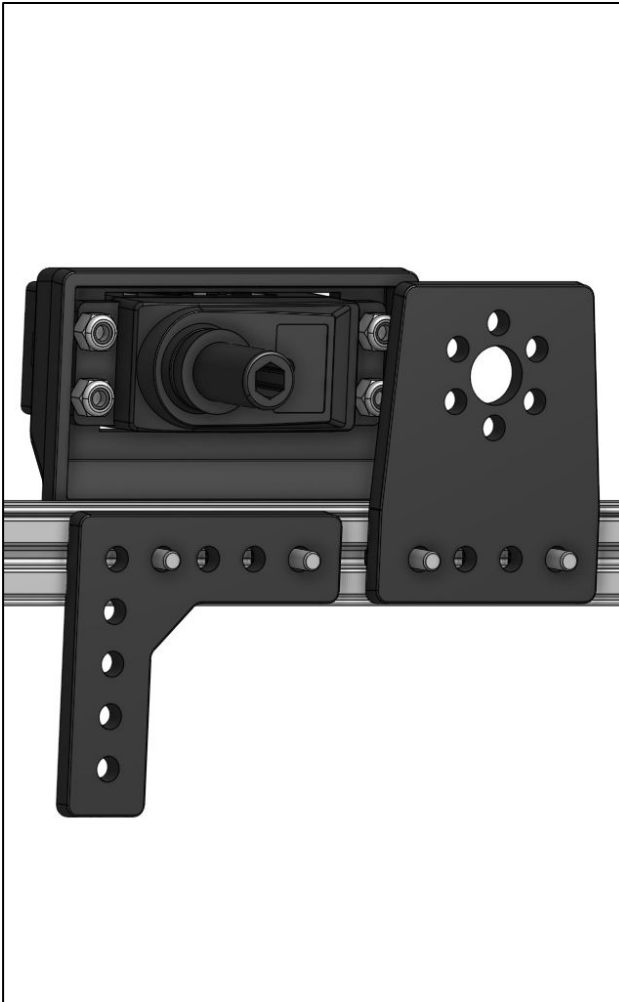

Get:

- 1 - 15mm Plastic 90 Degree Bracket
- 1 - 15mm Plastic Motion Bracket
- 4 - M3 x 8mm Hex Cap Screws
- 4 - M3 Standoff - 30mm

Slide four hex cap screws on the 225mm extrusion, then place the 90 degree bracket and motion bracket onto those screws as shown. Secure the screws with four 30mm M3 standoffs.

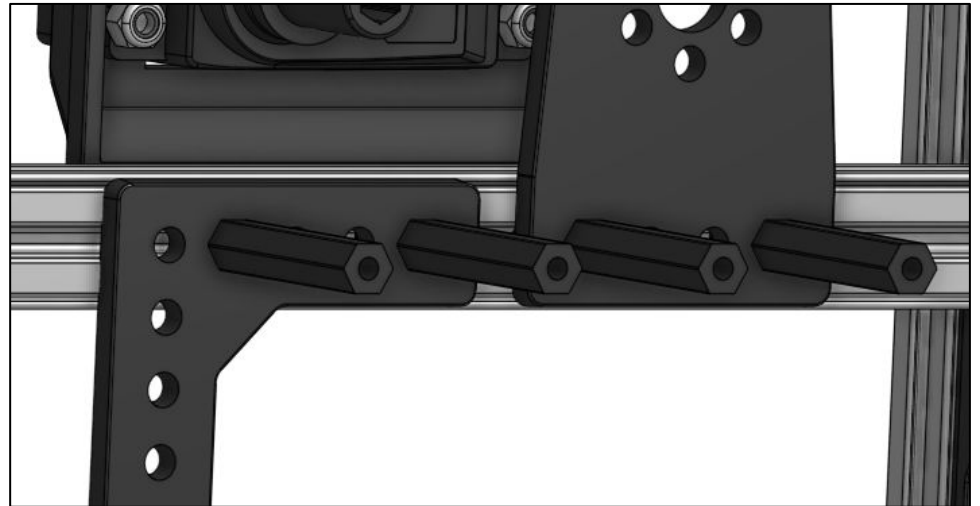

10

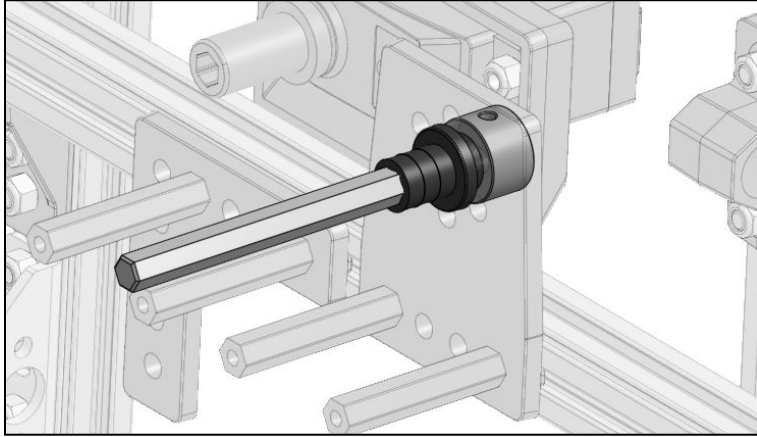

Get:

- 1 - 75mm Hex Shaft
- 1 - Shaft Collar
- 1 - Through Bore Bearing, Short
- 3 - 3mm Spacers

Slide a through bore bearing and three 3mm spacers onto a 75mm hex shaft. Slide the through bore bearing into the motion bracket as shown. Secure the shaft with a shaft collar on the back side of the motion bracket.

11

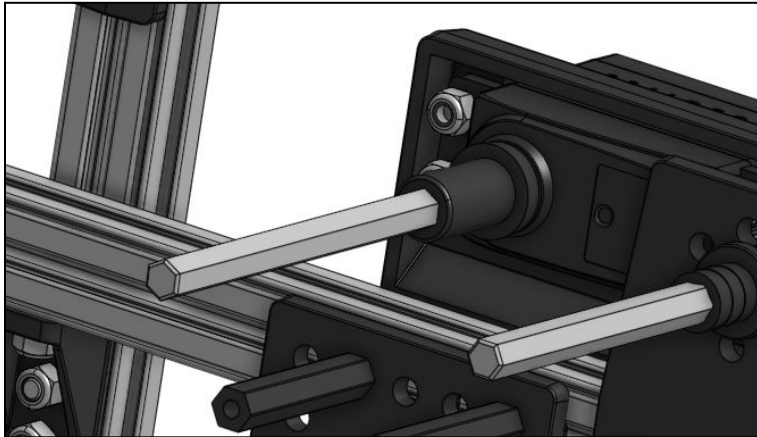

Get:

- 1 - 75mm Hex Shaft

Insert a 75mm hex shaft into the servo shaft adapter.

12



Get:

- 4 - 15mm Plastic Rod End Bracket
- 2 - 60 Tooth Plastic Gear
- 4 - M3 x 20mm Hex Cap Screws
- 4 - M3 Nyloc Nuts

Fasten the rod end brackets onto the gear as shown. Do this twice to have two separate gears with brackets.

13

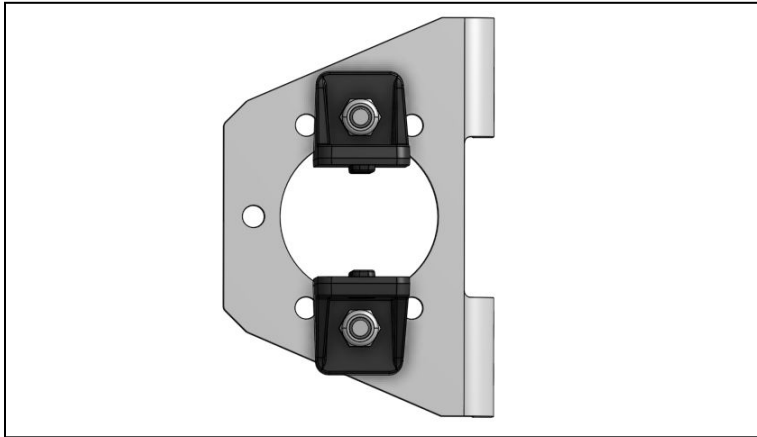

Get:

- 2 - UltraPlanetary Bent Mounting Bracket
- 4 - 15mm Plastic Lap Corner Bracket
- 4 - M3 x 8mm Hex Cap Screws
- 4 - M3 Nyloc Nuts

Fasten the corner brackets to motor bracket as shown. Do this twice.

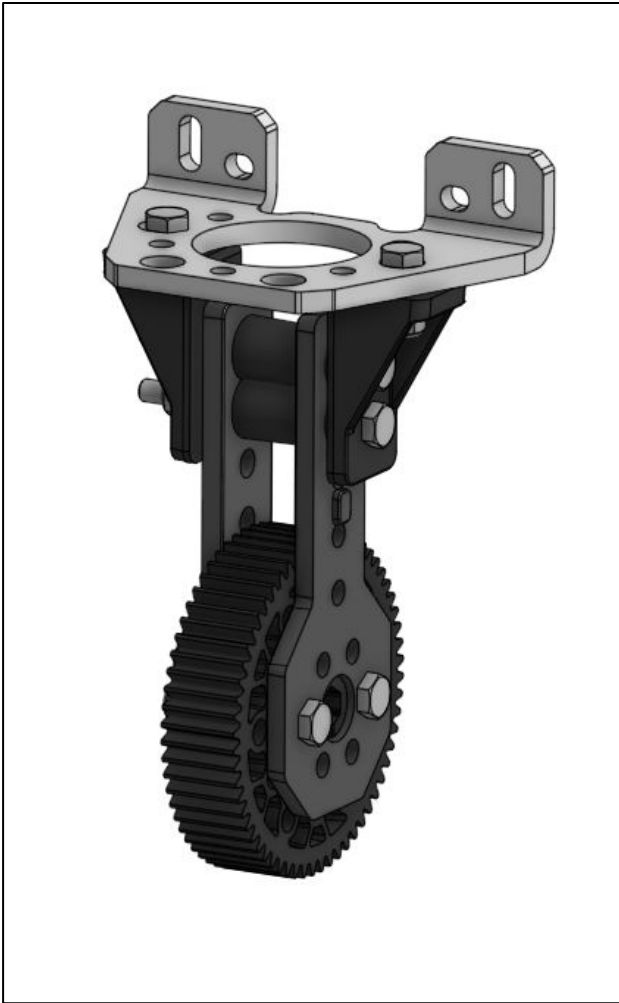

Get:

- 4 - M3 x 35mm Hex Cap Screw
- 4 - M3 Nyloc Nuts
- 4 - 15mm Spacers

Fasten the corner brackets to the rod end brackets as shown. Do this twice to have two mirrored assemblies as shown below.



15

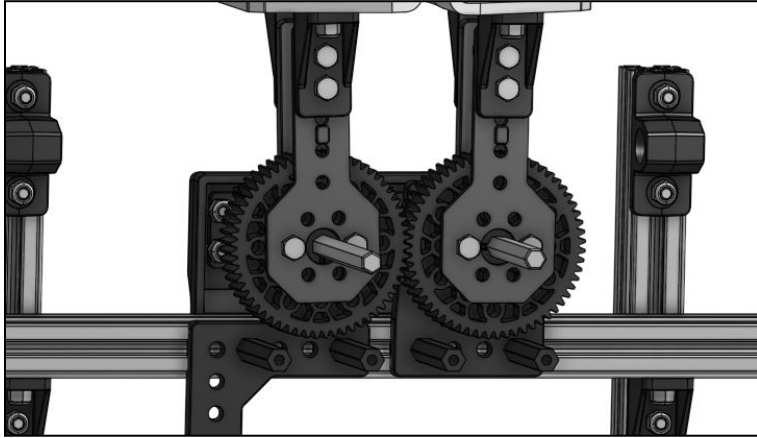

Get:

- Claw Assemblies

Slide the two 60 tooth gears from the previous steps onto the hex shafts as shown. The 60 tooth gears should be making significant contact and interaction with each other.

If the gears do not feel like they are interacting sufficiently, loosen the the standoffs on the “right” then slide the motion bracket over until the gears feel tight. Then tighten the standoffs.

16

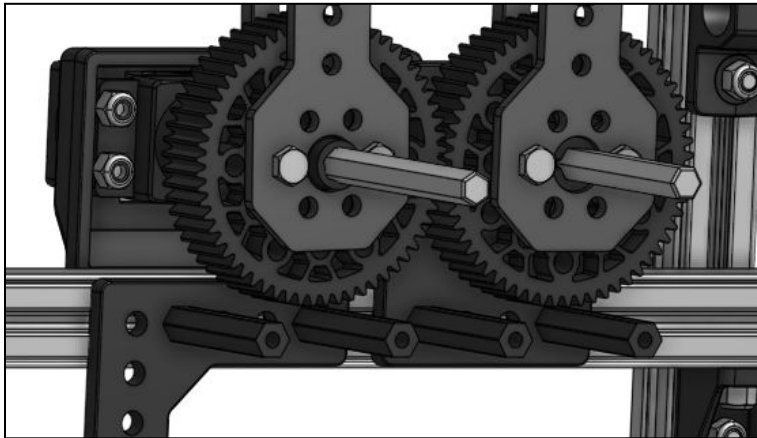

Get:

- 1 - 3mm Spacer

Slide the 3mm spacer onto the left hex shaft as shown.

17

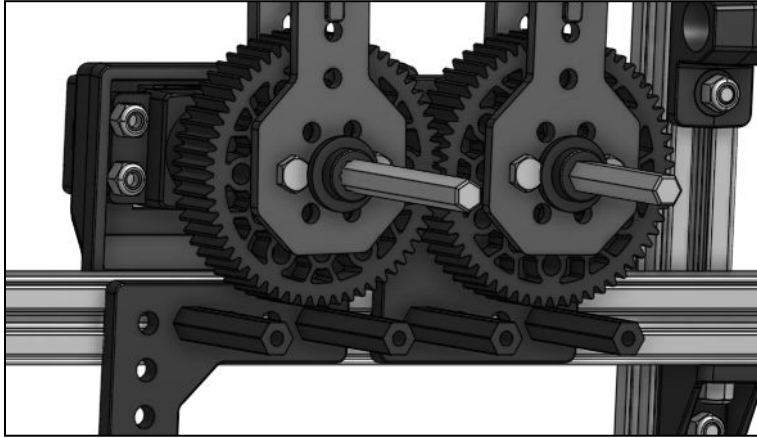

Get:

- 2 - Through Bore Bearings, Short

Slide the through bore bearings onto the hex shafts as shown. The short side of the bearing should be facing away from the servo.

18

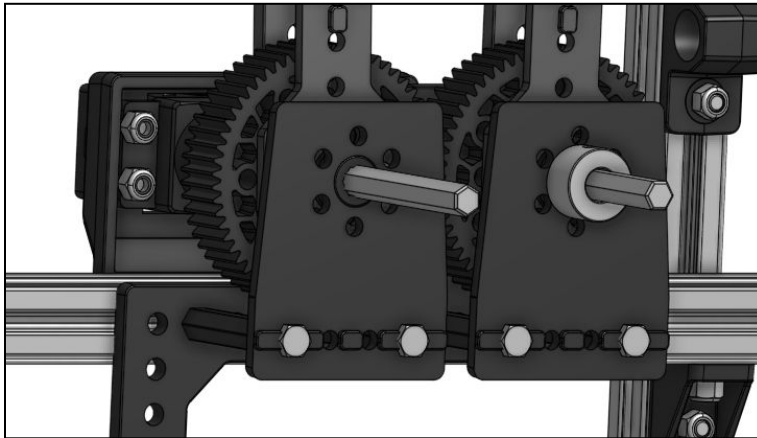

Get:

- 2 - 15mm Plastic Motion Bracket
- 4 - M3 x 8mm Hex Cap Screws
- 1 - Shaft Collar

Slide the two motion brackets onto the through bore bearings and secure them with hex cap screws into the standoffs. Secure the right hex shaft with a shaft collar as shown.

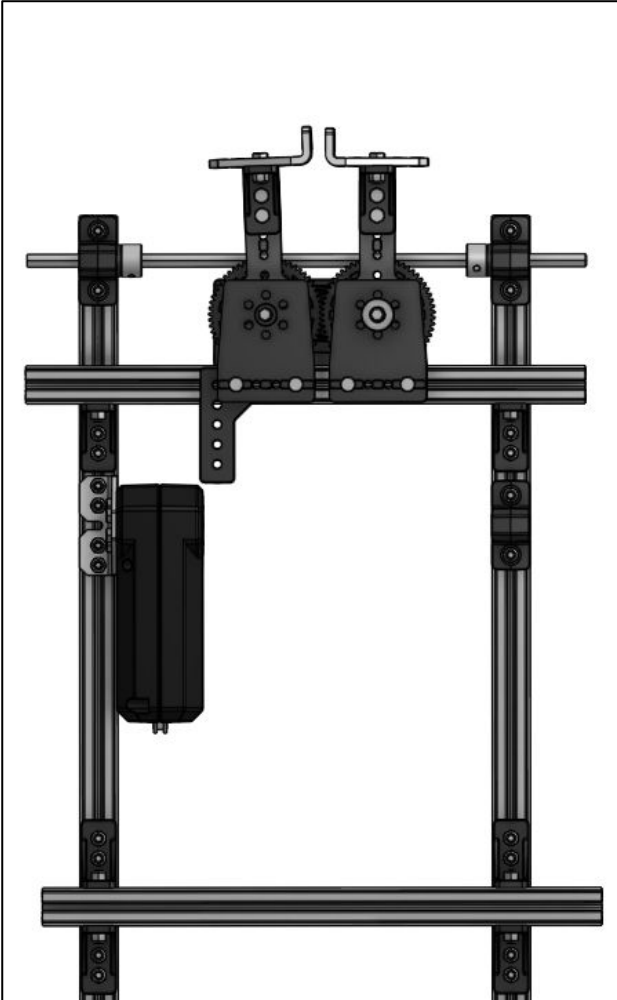

Get:

- 1 - 225mm Cut Hex Shaft
- 2 - Through Bore Bearings, Long
- 2 - Shaft Collars

Slide the 225mm cut hex shaft through the pillow bearing block then slide a through bore bearing long, two shaft collars, and then a through bore bearing long. Slide the through bore bearings into the pillow blocks then tighten the shaft collars.

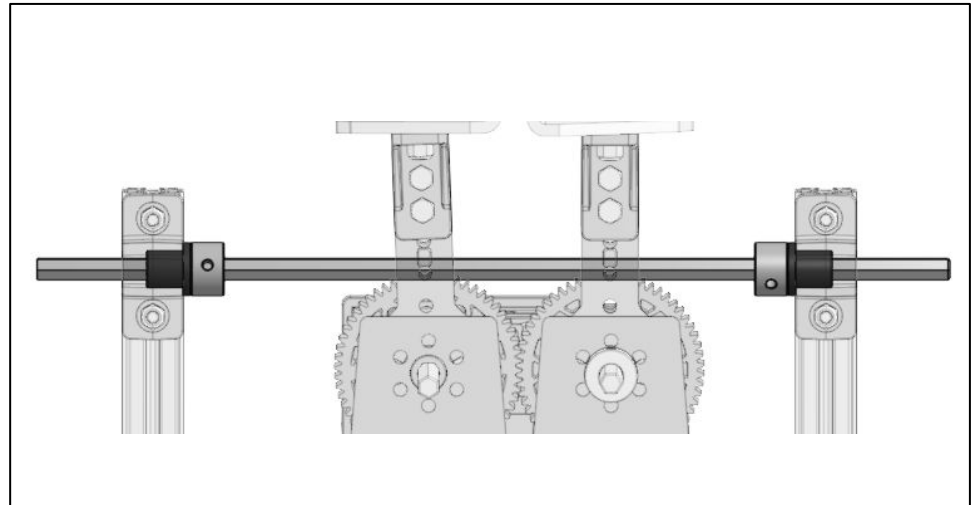

20

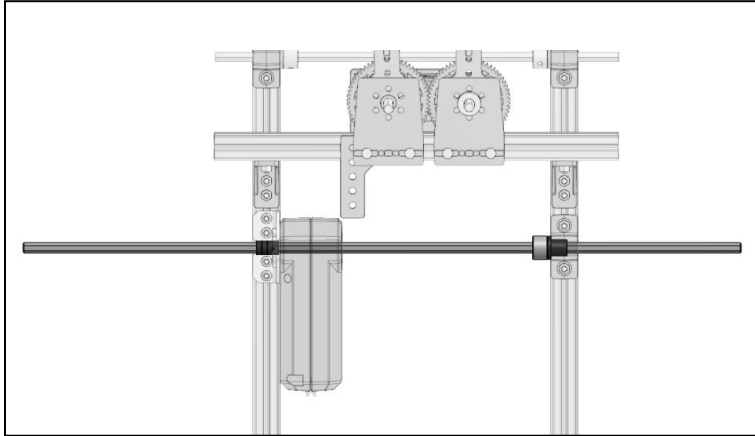

Get:

- 1 - 400mm Hex Shaft
- 1 - Through Bore Bearing, Long
- 1 - Shaft Collar
- 4 - 3mm Spacers

Slide a 400mm Hex Shaft through the Core Hex Motor then slide on a shaft collar and a Through bore bearing. Slide the through bore bearing into the pillow block. Center the shaft and tighten the shaft collar. Then slide four 3mm spacers onto the left side of the shaft as shown.

21

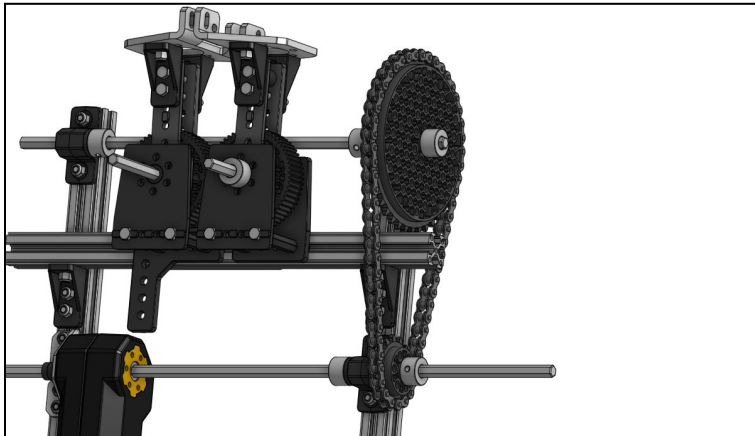

Get:

- 1 - 40 Tooth #25 Sprocket
- 1 - 15 Tooth #25 Sprocket
- 1 - 62 Link #25 Chain
- 2 - Shaft Collar

Wrap a 62 link #25 chain around both sprockets and slide them onto the two hex shafts as shown. Secure both sprockets with shaft collars.

Instructions on how to use a Chain Tool are linked at the beginning of this guide.

22

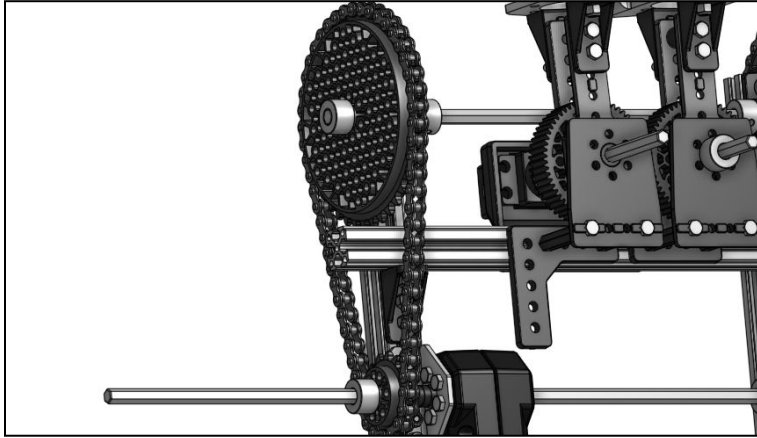

Get:

- 1 - 40 Tooth #25 Sprocket
- 1 - 15 Tooth #25 Sprocket
- 1 - 62 Link #25 Chain
- 2 - Shaft Collar

Wrap a 62 link #25 chain around both sprockets and slide them onto the two hex shafts as shown. Secure both sprockets with shaft collars.

Instructions on how to use a Chain Tool are linked at the beginning of this guide.

23

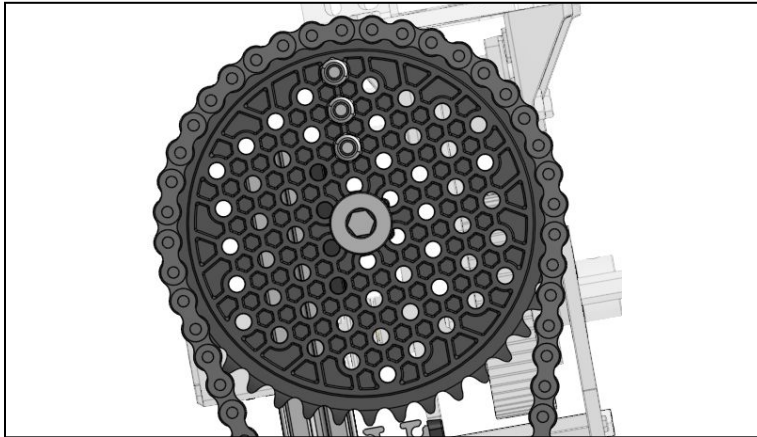

Get:

- 6 - M3 x 16mm Hex Cap Screws
- 6 - M3 Nyloc Nuts

Start three 16mm hex cap screws with the nuts on the outside of the 40 tooth gears but do not tighten them as these will be used later in final assembly. Do this on both sides.

Tower Assembly

Bill of Materials

Part number	Description	QTY.
REV-41-1767	45mm x 15mm C Channel - 248mm	1
REV-41-1432	15mm Extrusion - 420mm	3
REV-41-1431	15mm Extrusion - 225mm	2
REV-41-1359	M3 x 8mm Hex Cap Screws	46
REV-41-1360	M3 x 16mm Hex Cap Screws	15
REV-41-1361	M3 Nyloc Nuts	56
REV-41-1362	400mm Hex Shaft	2
REV-41-1326	Through Bore Bearings, Short	4
REV-41-1329	Through Bore Bearings, Long	6
REV-41-1317	15mm Bearing Pillow Blocks	6
REV-41-1327	Shaft Collars	10
REV-41-1324	3mm Spacer	4
REV-41-1147	High Strength Hex Hub	3
REV-41-1333	125 Tooth Plastic Gear	2
REV-41-1334	45 Tooth Plastic Gear	3
REV-41-1333	90 Tooth Plastic Gear	1
REV-41-1600	UltraPlanetary Gearbox & HD Hex Motor Kit	1
REV-41-1433	15mm Metal Bent Core Hex Motor Bracket	3
REV-41-1308	15mm Plastic 30 Degree Bracket	4

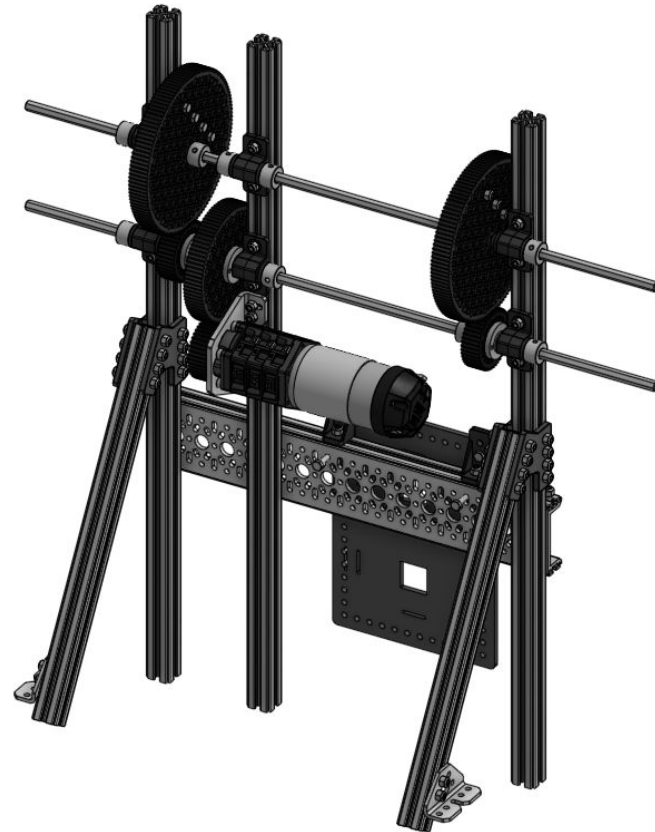

1

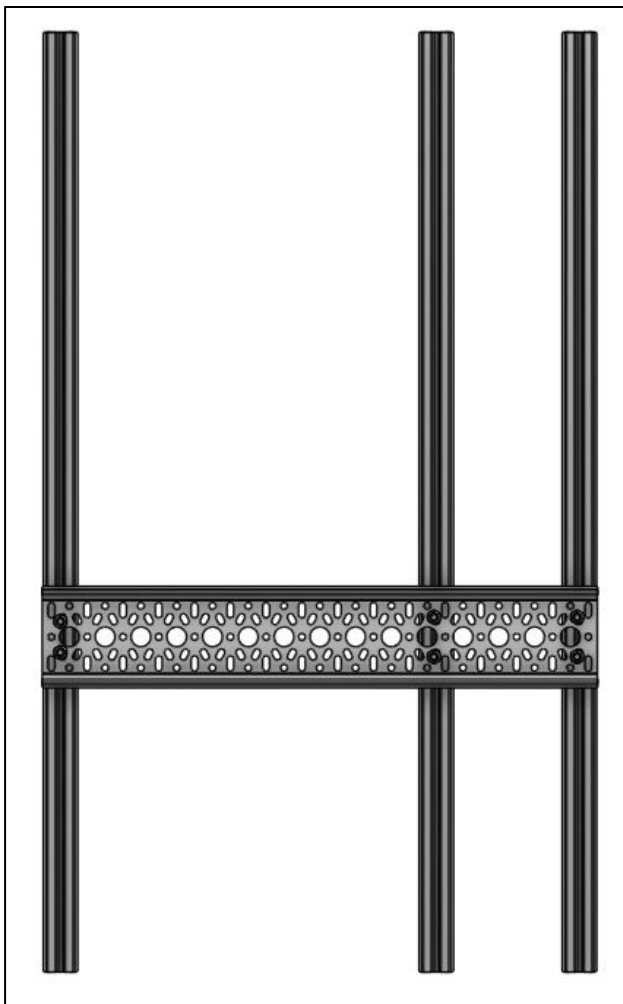

Get:

- 1 - 45mm x 15mm C Channel - 248mm
- 3 - 15mm Extrusion - 420mm
- 6 - M3 x 8mm Hex Cap Screws
- 6 - M3 Nyloc Nuts

Fasten a 248mm C Channel to three 420mm extrusion as shown.

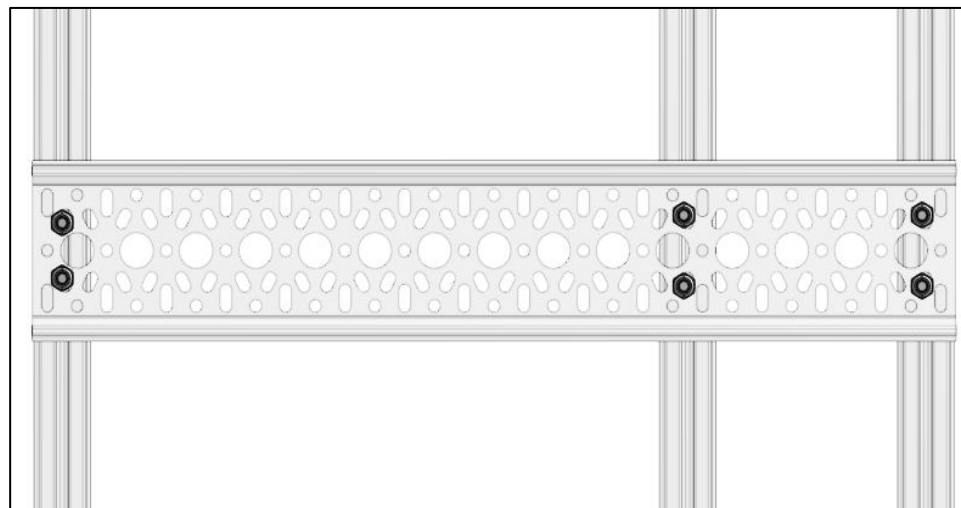



Get:

- 1 - 400mm Hex Shaft
- 1 - Through Bore Bearings, Short
- 3 - Through Bore Bearings, Long
- 3 - 15mm Bearing Pillow Blocks
- 3 - High Strength Hex Hub
- 6 - M3 x 8mm Hex Cap Screws
- 6 - M3 Nyloc Nuts
- 4 - Shaft Collars
- 2 - 3mm Spacer
- 2 - 45 Tooth Plastic Gear
- 1 - 90 Tooth Plastic Gear

Pre-load three bearing blocks. Slide the above onto a 400mm hex shaft as shown. From left to right, shaft collar, through bore short, bearing block, through bore long, 3mm spacer, 45 tooth gear, hex hub, 3mm spacer, 90 tooth gear, hex hub, bearing block, through bore long, 2 shaft collar, 45 tooth gear, hex hub, bearing block, through bore long, and shaft collar.

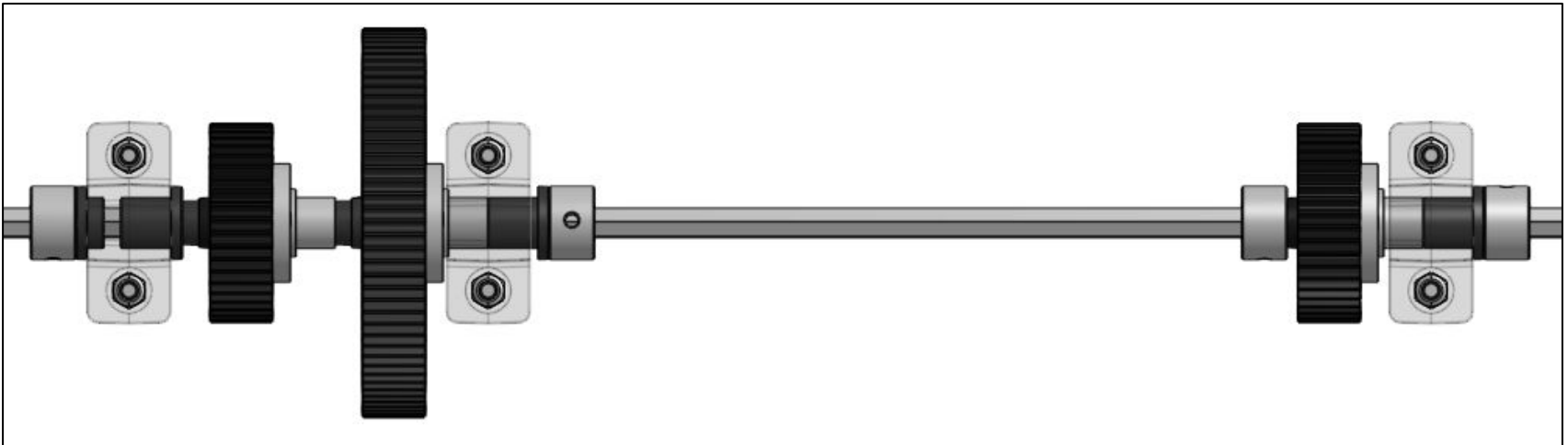

3

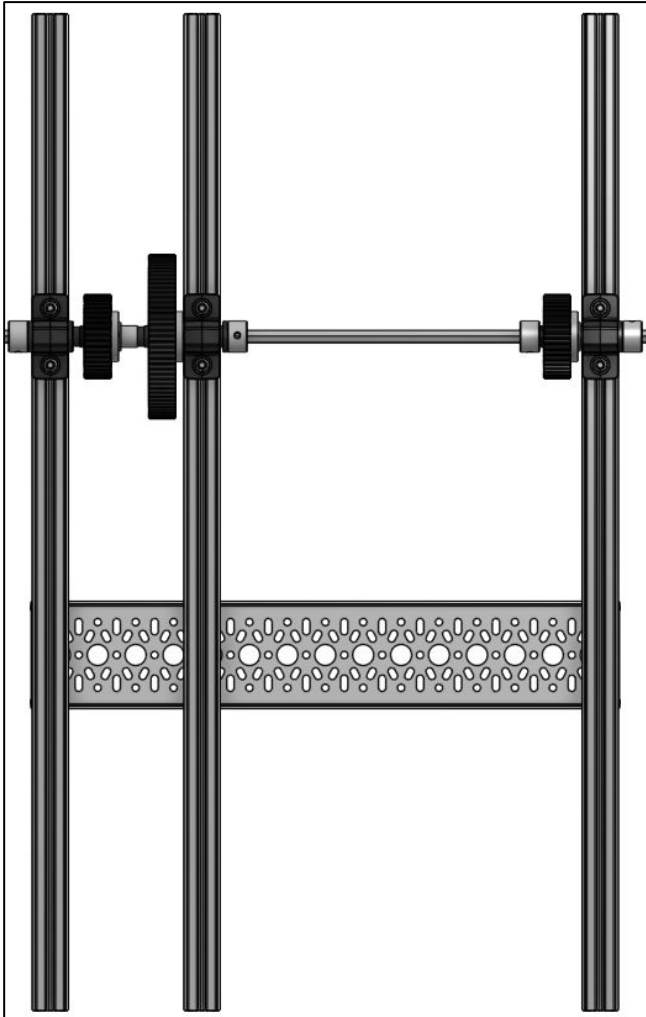

Get:

- Hex Shaft from previous step

Slide the bearing blocks onto the extrusion as shown. DO NOT TIGHTEN, keep the nuts loose for adjusting in a later step.

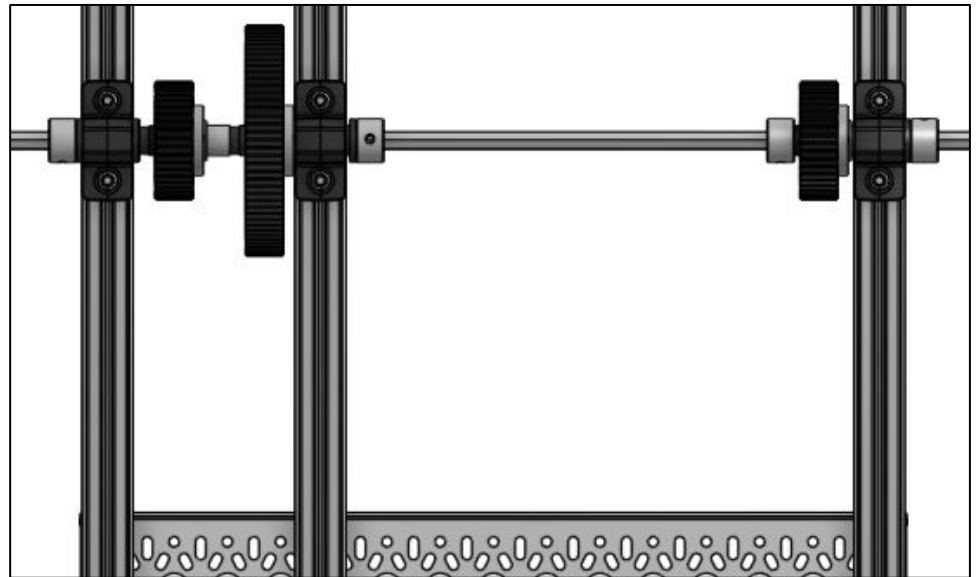



Get:

- 1 - 400mm Hex Shaft
- 3 - Through Bore Bearings, Short
- 3 - Through Bore Bearings, Long
- 3 - 15mm Bearing Pillow Blocks
- 6 - M3 x 8mm Hex Cap Screws
- 6 - M3 Nyloc Nuts
- 6 - Shaft Collars
- 2 - 3mm Spacer
- 2 - 125 Tooth Plastic Gear

Pre-load three bearing blocks. Slide the above onto a 400mm hex shaft as shown. From left to right, shaft collar, through bore short, bearing block, through bore long, 3mm spacer, 125 tooth gear, two shaft collar, through bore short, bearing block, through bore long, two shaft collar, 125 tooth gear, 3mm Spacer, through bore long, bearing block, through bore short, and shaft collar.

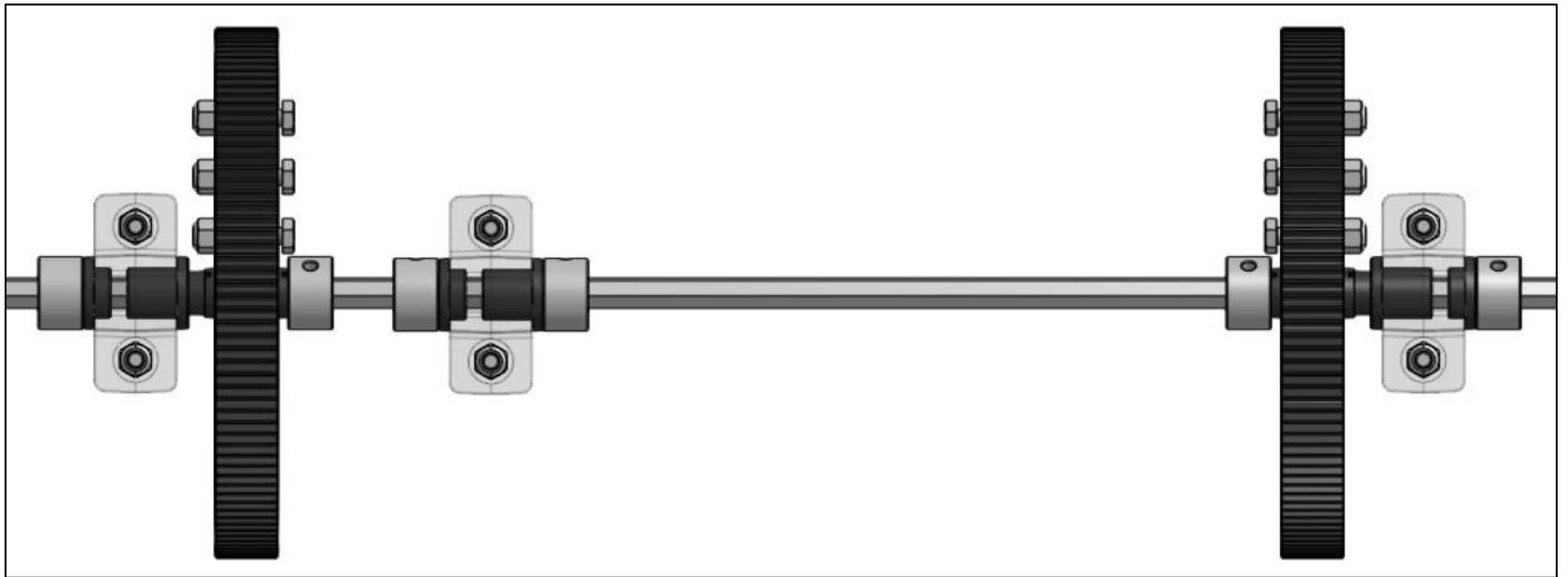

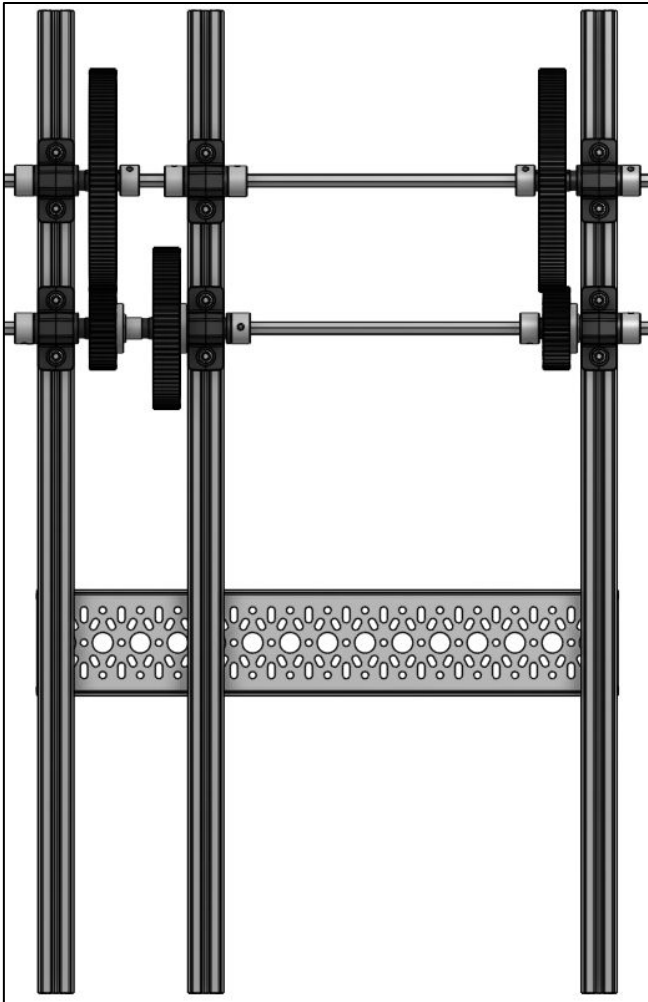

Get:

- Hex Shaft from previous step

Slide the bearing blocks onto the extrusion as shown, note this is the opposite side than the C Channel. The edge of the bearing blocks should be approximately 65mm from the end of the extrusion. This is important for the final assembly to match up later.

Slide the shaft from Step 3 up until the gears make significant contact and tighten all nuts.

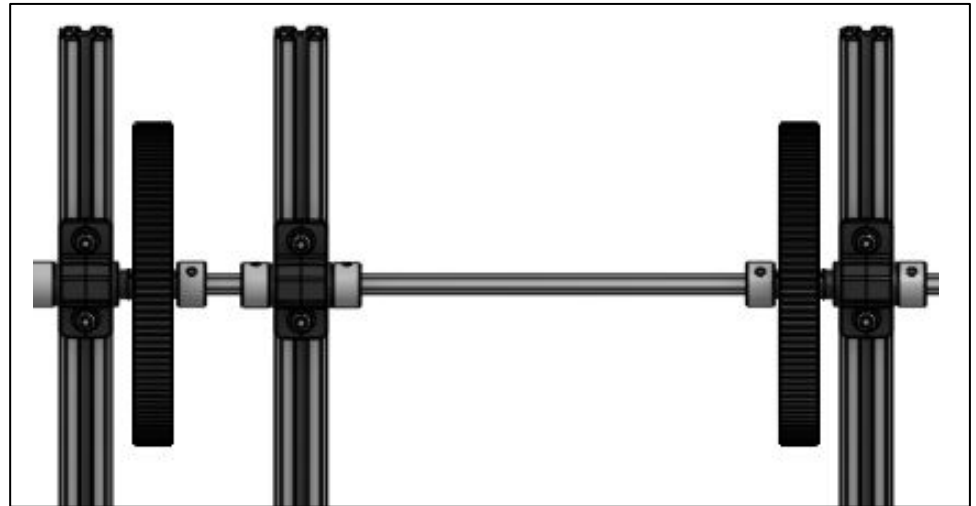

6

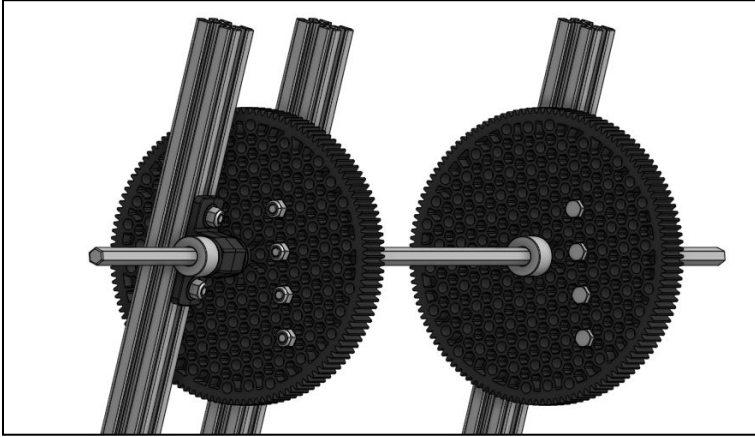

Get:

- 8 - M3 x 16mm Hex Cap Screws
- 8 - M3 Nyloc Nuts

Start four 16mm hex cap screws in the 125 tooth gears but do not tighten them as these will be used later in final assembly. Do this on both sides.

7

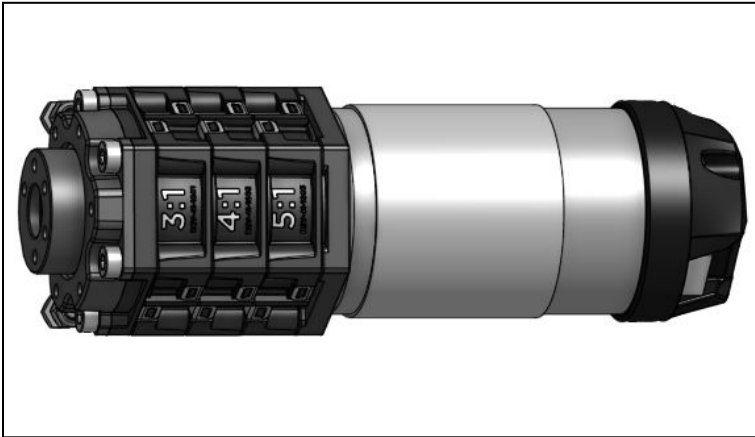

Get:

- 1 - UltraPlanetary Gearbox & HD Hex Motor Kit

Using the instructions for UltraPlanetary Gearbox assembly linked at the beginning of this guide assemble a 60:1 gearbox with the UltraPlanetary hex output.

8

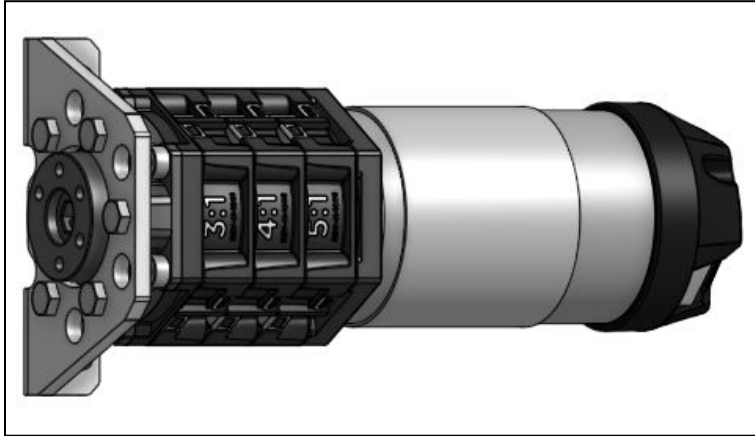

Get:

- 1 - UltraPlanetary Bent Mounting Bracket
- 5 - M3 x 8mm Hex Cap Screws

Fasten the UltraPlanetary mounting bracket to the UltraPlanetary output with five hex cap screws.

9

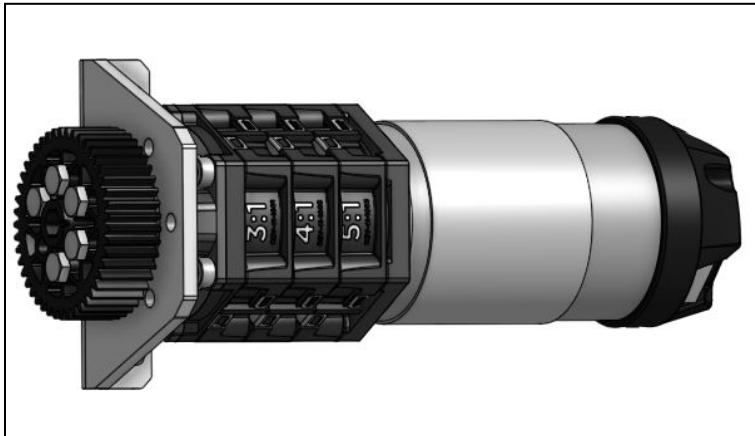

Get:

- 1 - 45 Tooth Plastic Gear
- 5 - M3 x 16mm Hex Cap Screws

Fasten a 45 tooth gear to the output using five hex cap screws.

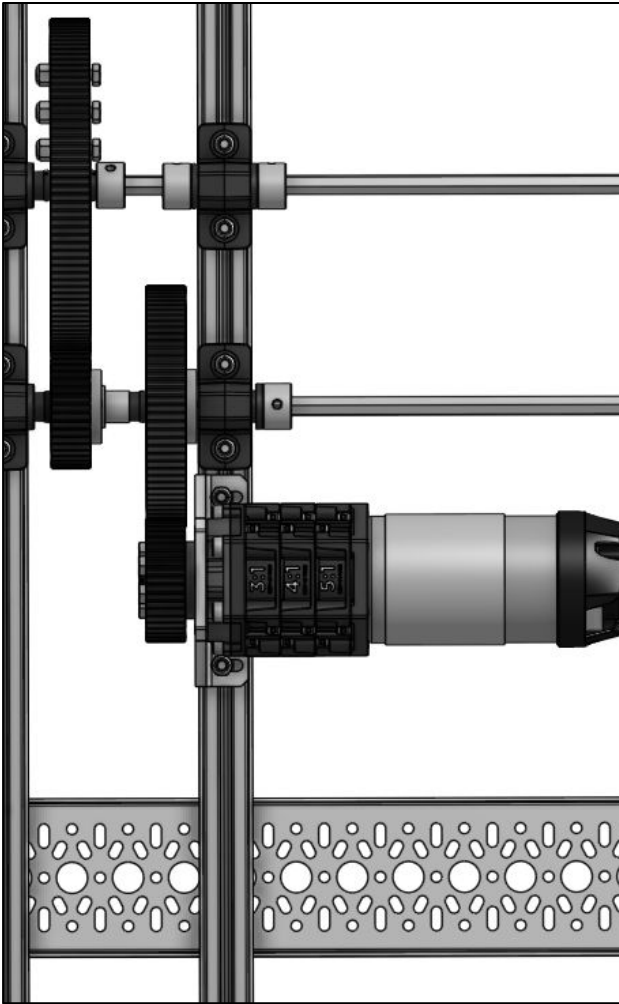

Get:

- 2 - M3 x 8mm Hex Cap Screws
- 2 - M3 Nyloc Nuts

Slide the motor bracket onto the extrusion as shown. The 45 tooth gears should be making significant contact and interaction with the 90 tooth gear. You may need to use a wrench for this step.

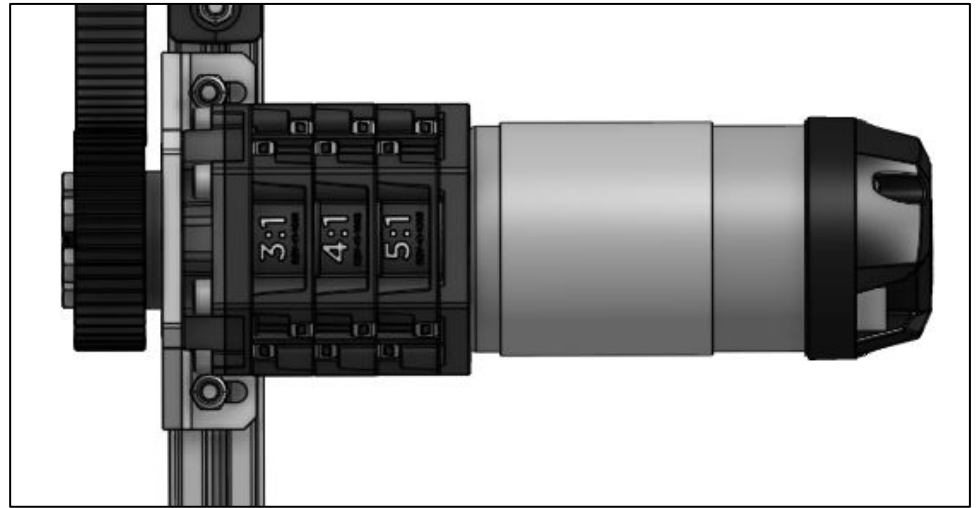

11



Get:

- 4 - 15mm Plastic 30 Degree Bracket
- 24 - M3 x 8mm Hex Cap Screws
- 24 - M3 Nyloc Nuts
- 2 - 15mm Extrusion - 225mm

Pre-load four 30 degree brackets then slide them onto the extrusion as shown. Slide 225mm extrusion into the brackets as shown. These may need to be adjusted later during final assembly.

12



Get:

- 2 - 15mm Metal Bent Core Hex Motor Bracket
- 4 - M3 x 8mm Hex Cap Screws
- 4 - M3 Nyloc Nuts

Pre-load two bent motor brackets then slide them onto the extrusion as shown. These may need to be adjusted later during final assembly.

Final Assembly and Electronics

Bill of Materials

Part number	Description	QTY.
REV-31-1595	Control Hub	1
REV-31-1387	Switch Cable and Bracket	1
REV-41-1166	Battery Holder Plate	1
REV-41-1373	Hook and Loop Fastener, 13.5mm x 2mm	2
REV-41-1161	Zipties, Black, 160mm	4
REV-41-1321	15mm Plastic Lap Corner Bracket	2
REV-41-1359	M3 x 8mm Hex Cap Screws	17
REV-41-1360	M3 x 16mm Hex Cap Screws	6
REV-41-1361	M3 Nyloc Nuts	23
-	Channel Drivetrain	1
-	Tower Assembly	1
-	Forearm Assembly	1
-	Intake Assembly	1

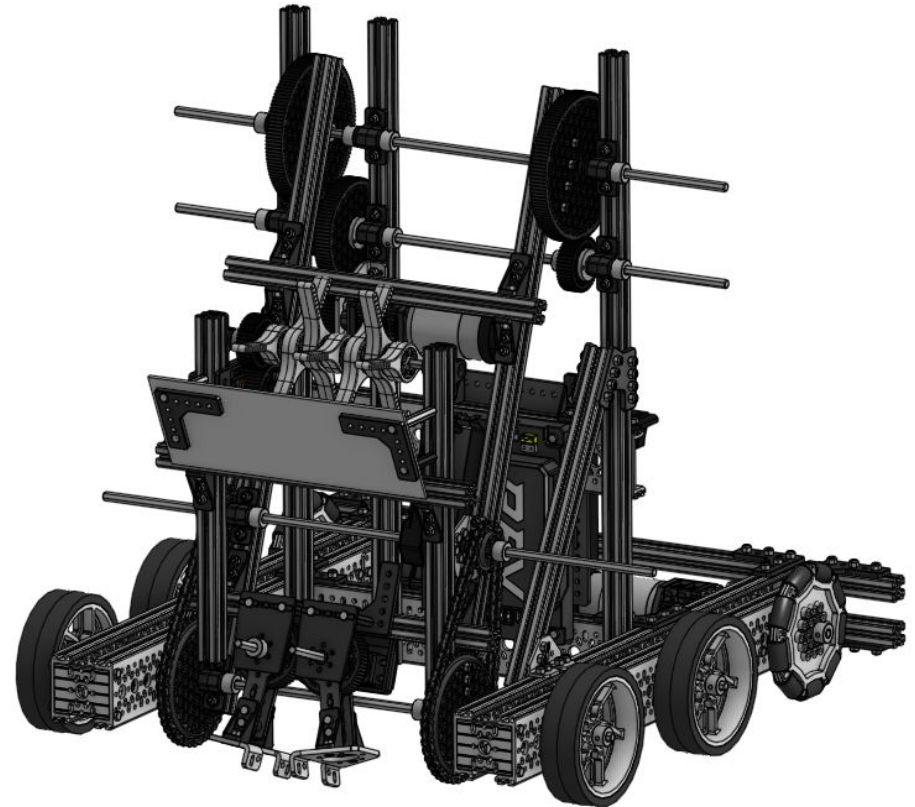

1

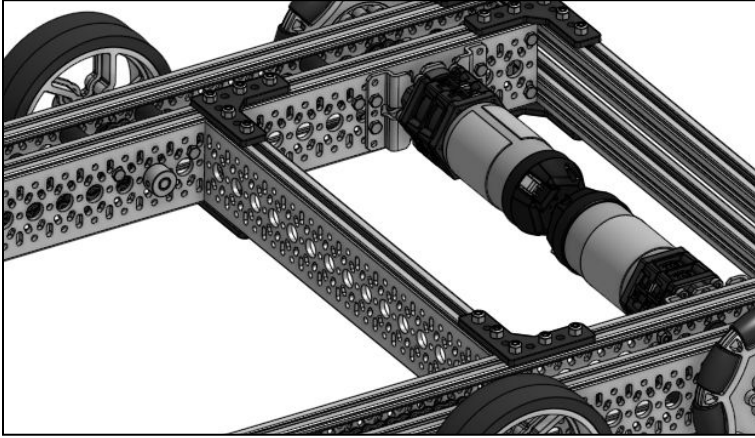

Get:

- 1 - Channel Drivetrain

Adjust the location of the 248mm C Channel approximately 145mm from the edge of the extrusion. You may need to loosen multiple brackets to slide the C Channel past shaft collars and screws.

2

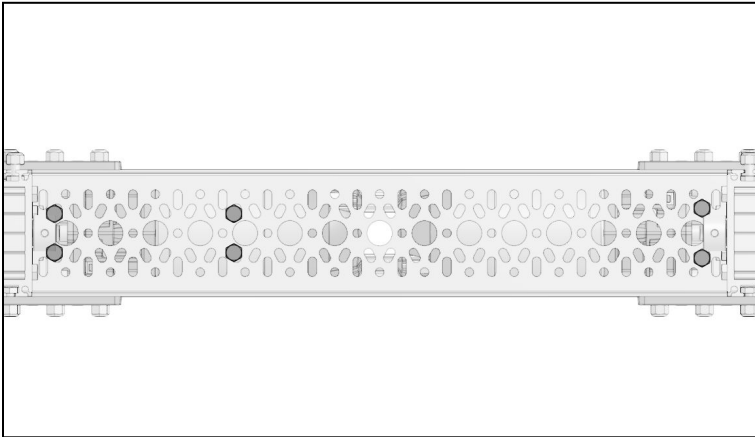

Get:

- 6 - M3 x 8mm Hex Cap Screws
- 6 - M3 Nyloc Nuts

Start hex cap screws in the locations shown. Keep these loose for the tower assembly.

3

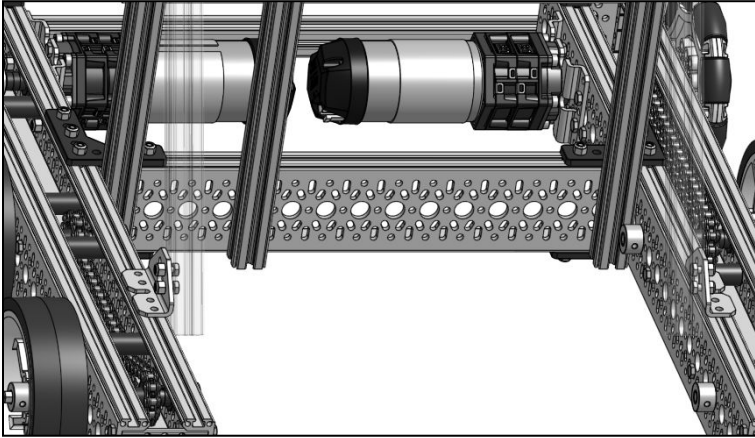

Get:

- 1 - Tower Assembly

Slide the tower assembly onto the hex cap screws from the previous step as shown. The end of the extrusion should be flush with the C Channel.

4

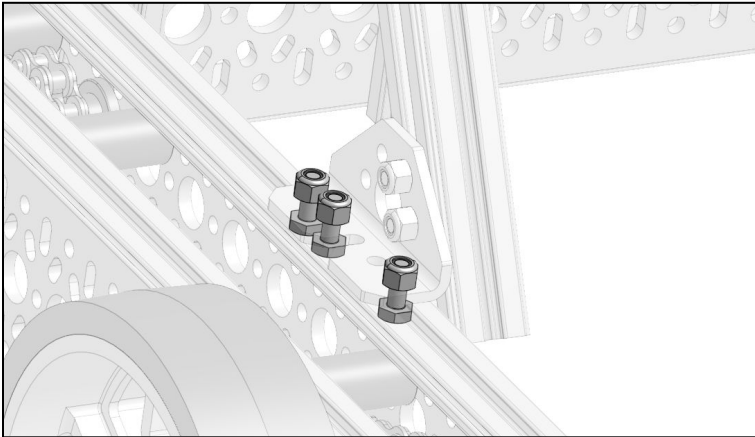

Get:

- 6 - M3 x 8mm Hex Cap Screws
- 6 - M3 Nyloc Nuts

Slide hex cap screws into the C Channel, slide the two bent motor brackets onto the screws, adjusting them for a stable support for the tower. Secure them with nyloc nuts. Do this on both sides.

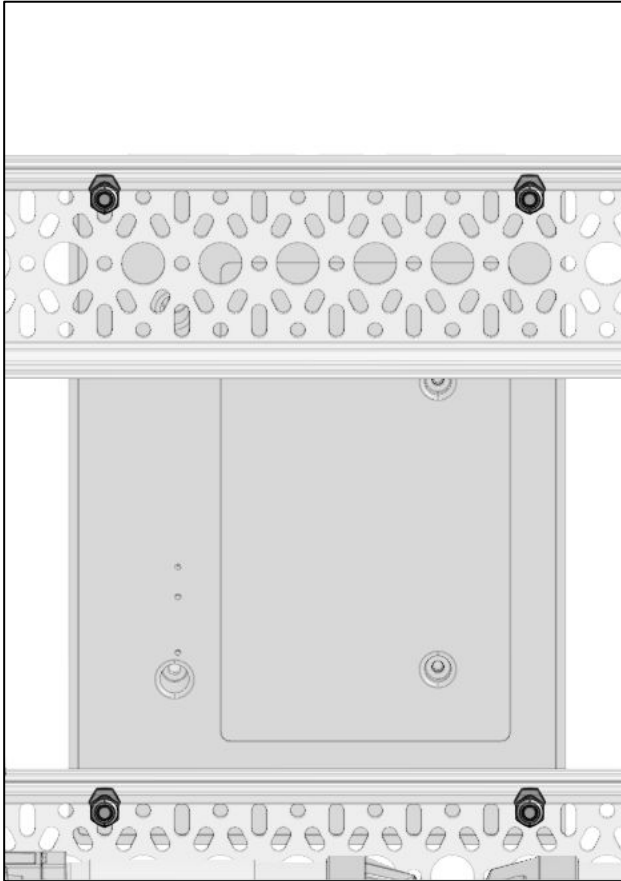

Get:

- 1 - Control Hub
- 4 - M3 x 8mm Hex Cap Screws
- 4 - M3 Nyloc Nuts

Fasten the control hub to the C Channel as shown.

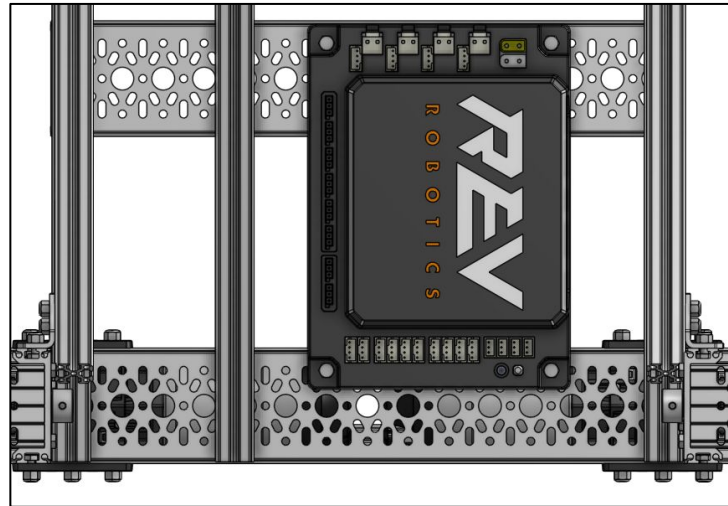

6

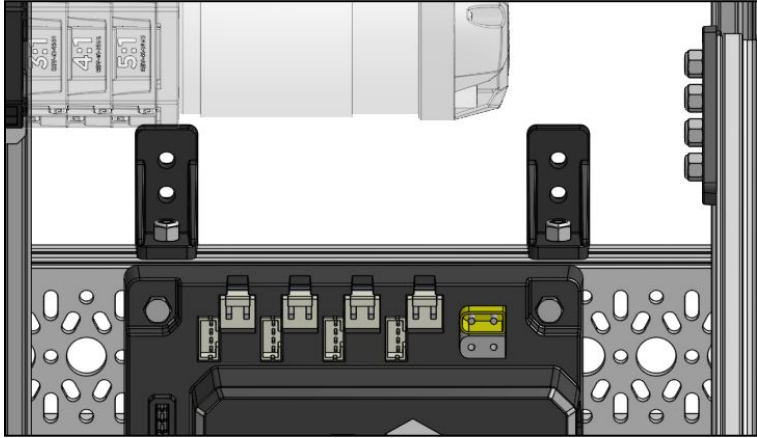

Get:

- 2 - 15mm Plastic Lap Corner Bracket
- 2 - M3 x 8mm Hex Cap Screws
- 2 - M3 Nyloc Nuts

Fasten the corner brackets to the C Channel as shown.

7

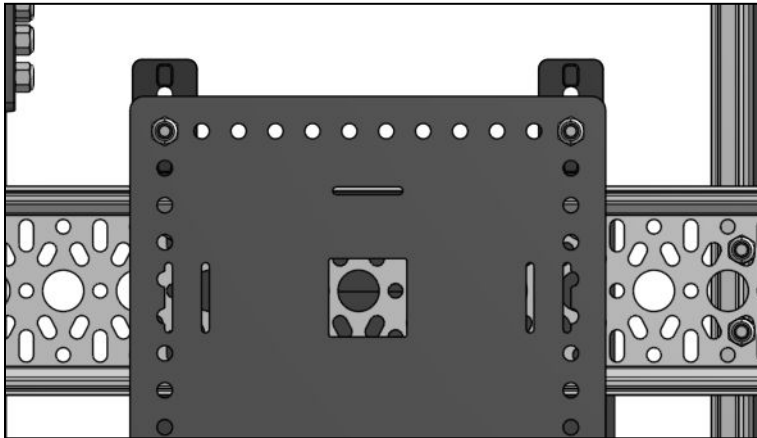

Get:

- 1 - Battery Holder Plate
- 2 - M3 x 8mm Hex Cap Screws
- 2 - M3 Nyloc Nuts
- 2 - Hook and Loop Fastener

Fasten the battery holder plate to the corner Brackets as shown. Feed the hook and loop fastener through desired holes in the battery holder.

8

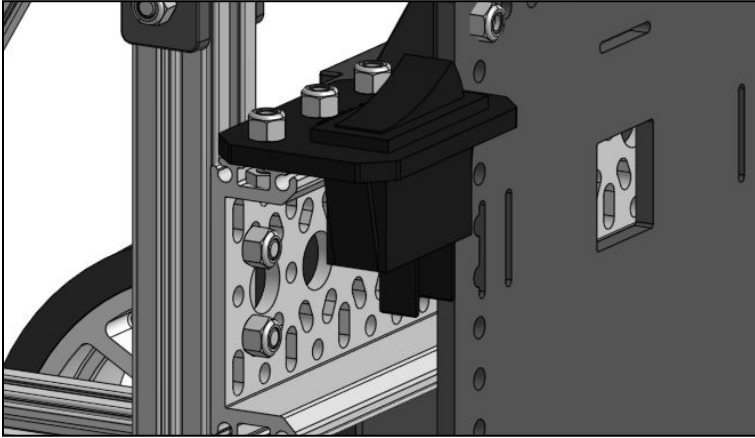

Switch Cable and Bracket Option 1

Get:

- 1 - Switch Cable and Bracket
- 3 - M3 x 8mm Hex Cap Screws
- 3 - M3 Nyloc Nuts

Fasten the switch and bracket to the C Channel as shown using hex cap screws.

8

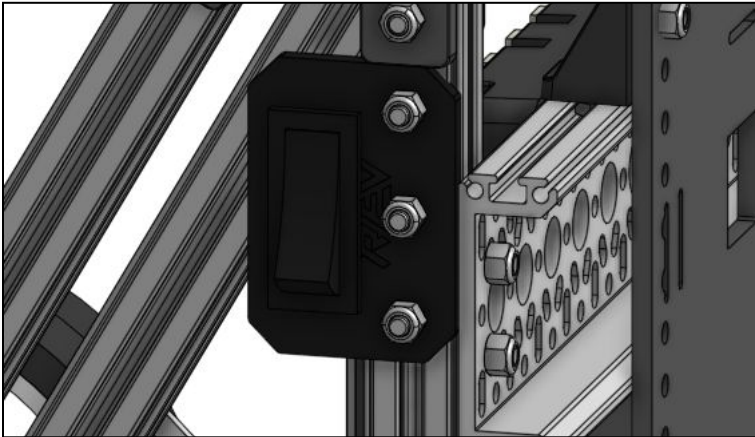

Switch Cable and Bracket Option 2

Get:

- 1 - Switch Cable and Bracket
- 3 - M3 x 8mm T-Slot Screws
- 3 - M3 Nyloc Nuts

Fasten the switch and bracket to the extrusion as shown using T-Slot Screws.

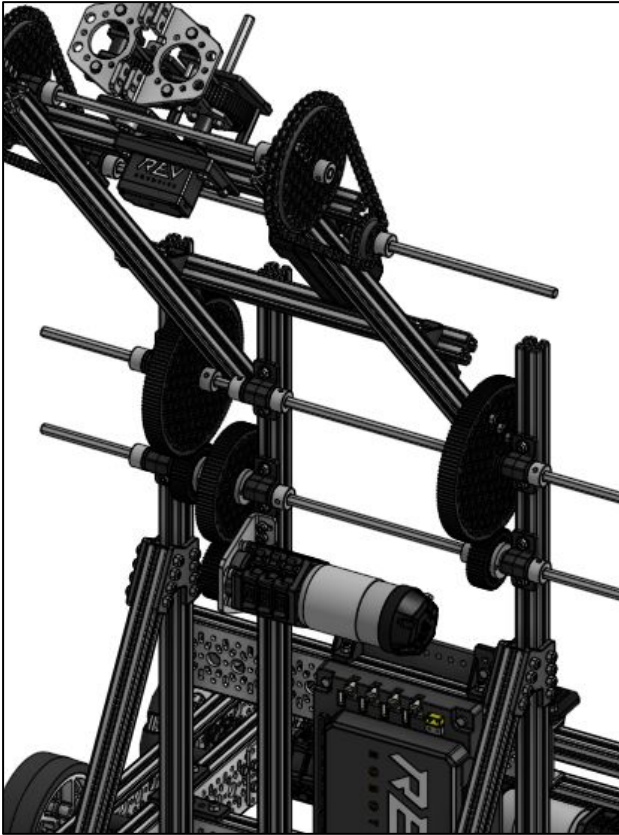

Get:

- Forearm Assembly

Slide the forearm assembly onto the eight hex cap screws in the 125 tooth gears of the tower. The end of the extrusion should not extend past the teeth of the gear. Tighten the nyloc nuts.

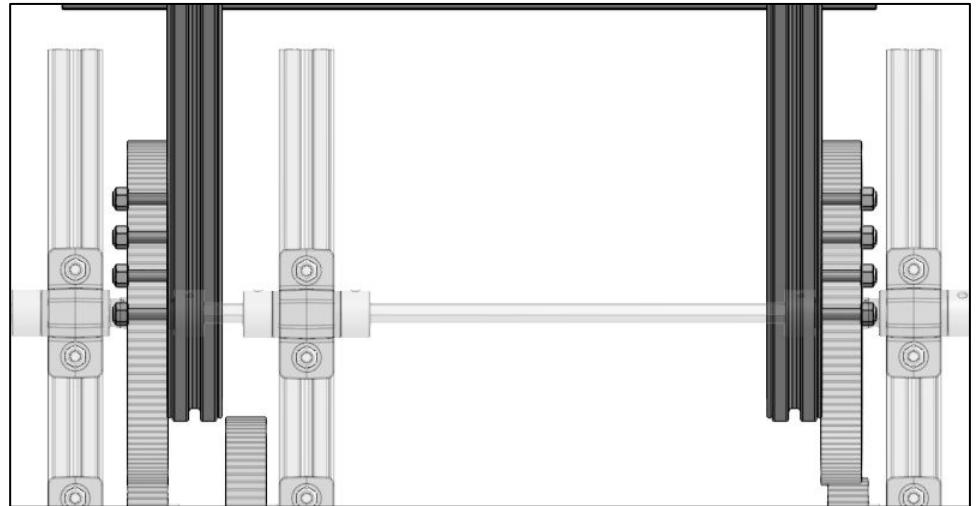



Get:

- 1 - Intake Assembly

Slide the intake assembly onto the six hex cap screws in the 40 tooth sprocket of the forearm. The end of the extrusion should not extend past the last hex cap screw and should rest on the bearing block as shown. This will serve as a hard stop of your intake. Tighten the nyloc nuts.

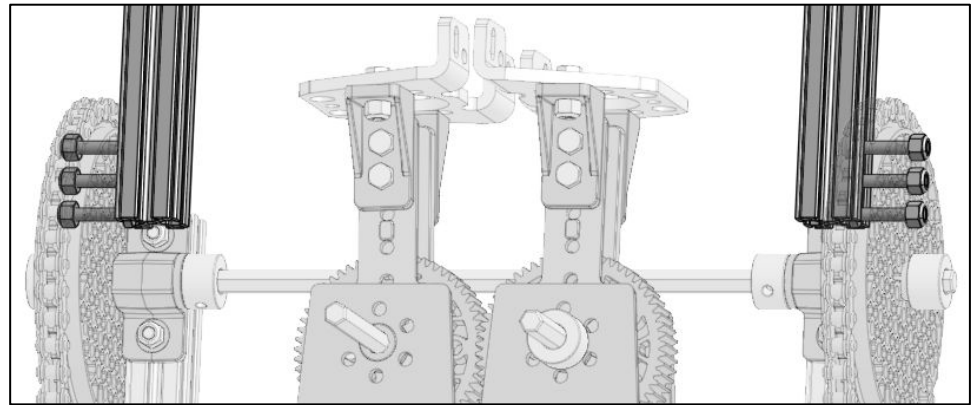

11

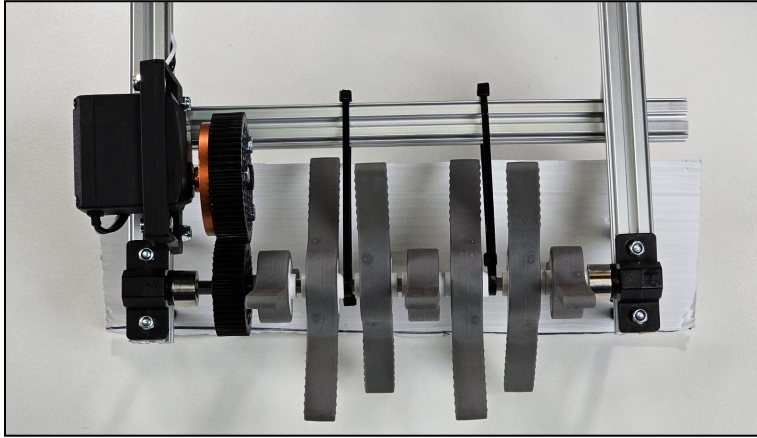

Get:

- 4 - Zipties 160mm

Connect two zipties together to make a longer one. Then wrap the zipties around the extrusion and intake hex shaft as shown. Tighten them so they stay complaint. Do not tighten them all the way. Trim any excess.

Congratulations! You are done!



2024-25 REV DUO FTC Starter Bot Build Guide

