

1" 135 DEGREE BRACKET

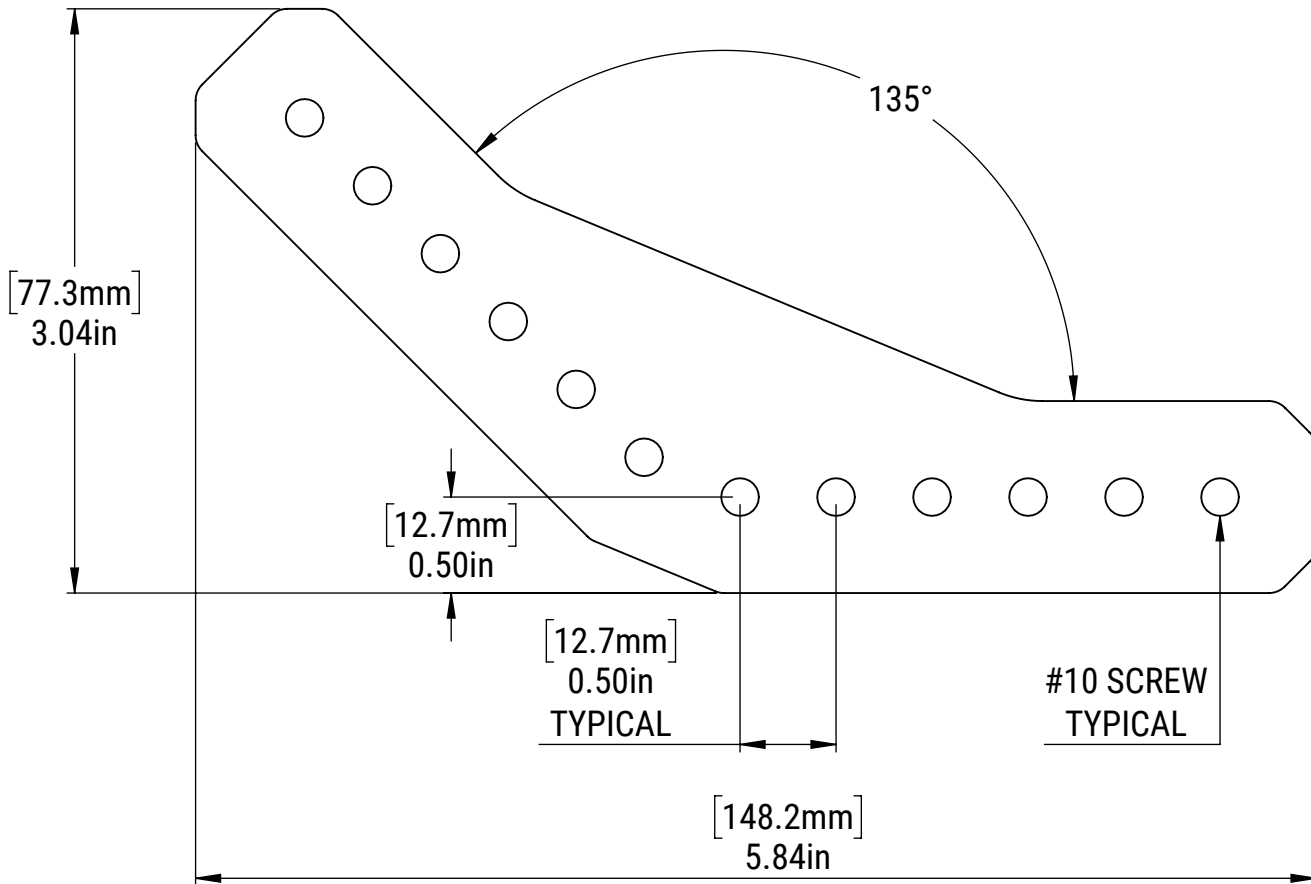

MM SHEET TOLERANCES:

X ± 0.50 MM
X.X ± 0.10 MM
X.XX ± 0.05 MM
ANGLES ± 2°

INCH SHEET TOLERANCES:

X ± 0.1 IN
X.X ± 0.02 IN
X.XX ± 0.004 IN
X.XXX ± 0.002 IN
ANGLES ± 2°

MATERIAL:

5052-H32 ALUMINUM
0.125"/3mm

DATE: 1/22/2020