

12T GT2 3MM PITCH PULLEY

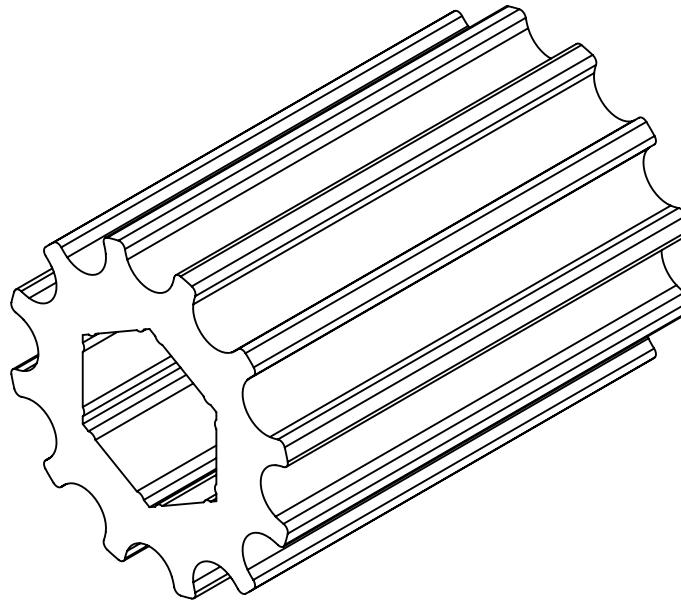
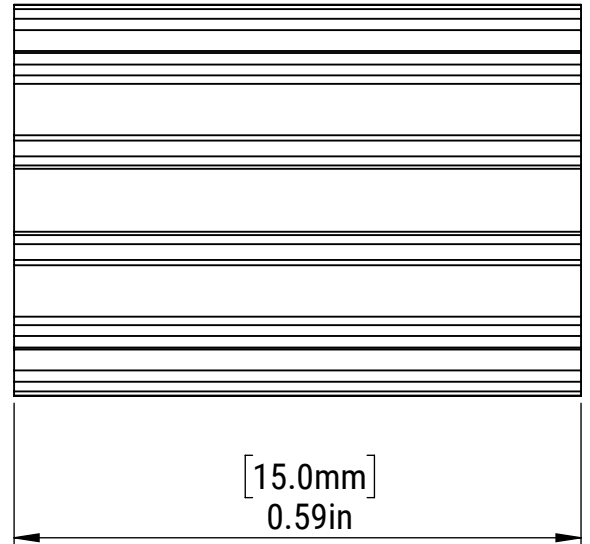
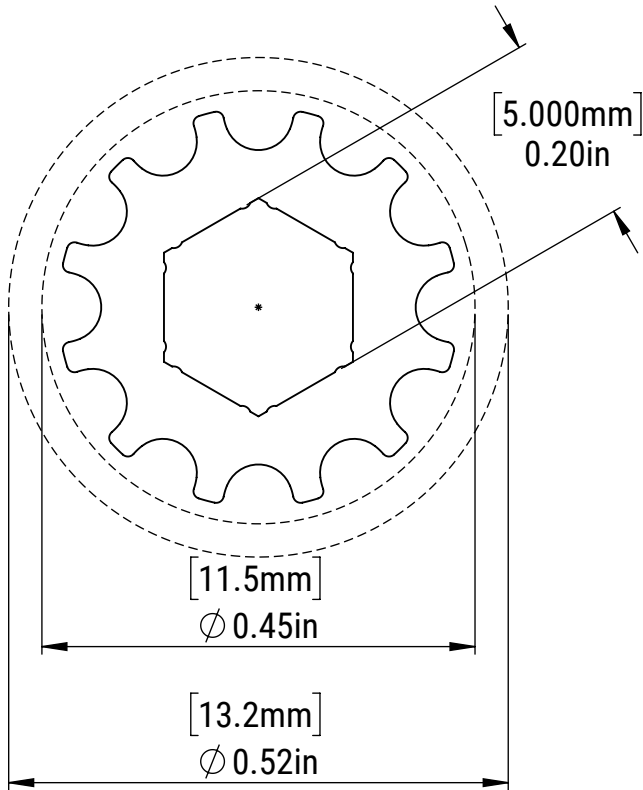

MM SHEET TOLERANCES:

X ± 0.50 MM
X.X ± 0.10 MM
X.XX ± 0.05 MM
ANGLES ± 2°

INCH SHEET TOLERANCES:

X ± 0.1 IN
X.X ± 0.02 IN
X.XX ± 0.004 IN
X.XXX ± 0.002 IN
ANGLES ± 2°

MATERIAL:

ACETAL

DATE: 7/31/2020